



EVENPRODUCTS

water for life

incorporating

Logic Irrigation Limited

LOGIC
Irrigation

EVENPRODUCTS
water for life

Aquarius Universal
Control is Everything

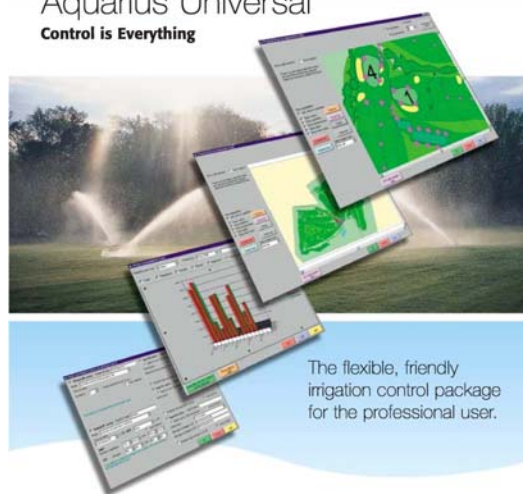

The flexible, friendly irrigation control package for the professional user.

logic aquarius universal operating instructions Microsoft® Windows® 95, 98 or NT



CONTENTS

CONTENTS	1
INSTALLING THE AQUARIUS.....	3
PARTS REQUIRED FOR THE INSTALLATION OF THE AQUARIUS UNIVERSAL PC SYSTEM.	3
<i>Minimum specification for the PC:</i>	3
<i>Aquarius Translators.</i>	3
<i>An RS232 to RS485 converter.</i>	4
INSTALLATION:	5
HARDWARE.....	5
SECURITY KEY:.....	5
SOFTWARE:	6
LOGIC AQUARIUS OPERATION MANUAL	8
WINDOWS BASICS.....	8
STARTING THE AQUARIUS UNIVERSAL PROGRAM.....	10
METHOD 1: USING A SHORT-CUT ICON ON THE WINDOWS DESKTOP	10
METHOD 2: USING THE START BUTTON FROM THE WINDOWS TASKBAR.....	10
METHOD 3: AUTOMATICALLY STARTING WHEN WINDOWS STARTS.	10
<i>Windows Passwords:</i>	10
<i>Power Saving Features:</i>	10
LOGGING ON:	10
AQUARIUS UNIVERSAL MAIN SCREEN.....	11
THE STANDARD ACTIVITIES FORM.....	12
NAVIGATING A FORM	13
<i>A general description of the various buttons.....</i>	13
DOWNLOADING INFORMATION.....	14
SETTING UP THE USERS.	15
SETTING UP THE DATABASE	16
THE GENERAL DATABASE	16
<i>Districts form</i>	17
<i>Area form:</i>	18
<i>Valve location type form:</i>	19
<i>Valve location su+b type form:</i>	20
<i>Valve type form:</i>	21
<i>Sprinkler type form:</i>	22
<i>The sprinkler pressure form:</i>	23
<i>The Defaults form:</i>	24
THE SITE DATABASE.....	25
<i>Pump House:</i>	25
<i>Pumps for a specific Pump House</i>	26
<i>Hydraulic zone</i>	27
<i>Pipe runs for Hydraulic Zone</i>	28
<i>Controller Zone</i>	29
<i>Pipe runs for Hydraulic Zone</i>	31
<i>Valves</i>	32
<i>Description of the Valve Form fields:</i>	33
<i>Sprinklers</i>	35
DOWNLOADING INFORMATION INTO THE TRANSLATORS.....	36
CREATING A PROGRAM:.....	37

EDITING A PROGRAM	38
<i>Method 1: To program an individual station with a basic time:</i>	38
<i>Method 2: To program a group of stations with the same basic time:</i>	38
<i>Method 3: To program an individual station by precipitation:</i>	39
<i>Method 4: To program a group of stations with the same basic time:</i>	39
ENTERING A SCHEDULE:	40
MANUAL OPERATION	43
DIAGNOSTIC OPERATION	44
EDITING A DIAGNOSTICS PROGRAM	45
<i>Method 1: To program an individual station with a basic time:</i>	45
<i>Method 2: To program a group of stations with the same basic time:</i>	45
<i>Method 3: To program an individual station by precipitation:</i>	46
<i>Method 4: To program a group of stations with the same basic time:</i>	46
REMOTE CONTROL	48
REMOTE CODES AVAILABLE:	48
<i>Emergency shut down:</i>	49
<i>Pause:</i>	49
<i>Resume:</i>	49
<i>Clear Buffer:</i>	49
<i>Running a Diagnostics program:</i>	49
<i>Kill Diagnostics:</i>	49
<i>Bypassing delays:</i>	49
LOGBOOKS	50
THE MAIN LOGBOOK	50
WATER CONSUMPTION LOGBOOK	51
AQUARIUSRUN	52
ADDITIONAL INFORMATION IN THE CONTROLLER MONITOR SCREEN.	53
APPENDIX A: CHANGING THE DISTRICT AND AREA LABELS IN AQUARIUS.	54
APPENDIX B: SETTING PREFERENCES FOR INDIVIDUAL USERS	55
APPENDIX C: FILES STORED IN AQUARIUS	56
APPENDIX D: AQUARIUS MENUS	57
AQUARIUS UNIVERSAL MENU	57
AQUARIUSRUN MENU	58
APPENDIX E: ADDING A REMOTE CONTROL TO AQUARIUS	59
APPENDIX F: LOGIC AQUARIUS DATABASE INFORMATION:	60
GENERAL SITE INFORMATION	60
<i>Courses</i>	60
<i>Valve Types</i>	60
<i>Holes</i>	61
<i>Sprinkler Make and performance.</i>	62
<i>Valve Types:</i>	63
<i>Valve Sub types:</i>	63
INFORMATION ABOUT WHAT IS INSTALLED AND HOW THE SYSTEM IS SET UP.	64
<i>Pump House: Please enter the pump house and the information regarding the pumps and performance.</i>	64
<i>Pumps within a Pump House: For the delivery please enter the required performance for the system.</i>	64
<i>Hydraulic Zones: Please enter in how many hydraulic zones and what the expected flow for each zone will be...</i> ..	64
<i>Hydraulic Zone Pipe Run: Please enter the information regarding the pipe network for each hydraulic zone.</i> ..	65
<i>Electrical Zone information: Please enter the electrical zones details.</i>	66
<i>Zone Wire Run: Zone Wire Run: Please enter the information regarding the wire network for each zone.</i>	66
<i>Valve Information: This is the main field that requires the most information.</i>	67

Installing the Aquarius

Parts Required for the Installation of the Aquarius Universal PC system.

Minimum specification for the PC:

Pentium II 350Mhz
 64MB Ram
 At least 100MB free hard disk space.
 CD Rom
 Windows 95, 98 or NT.
 PS/2 Mouse

8MB Graphics card (if the graphics option is wanted)
 15" Monitor (17" Recommended)
 56K Modem
 PcAnywhere
 2 spare RS232 serial ports.
 Printer.

Aquarius Translators.

These units are the modified version of the Tonick translator. The software in the Aquarius version of the Translator is slightly different and if an existing translator is being used the unit will need updating to contain the new software. Failure to do so will mean that the translator will not communicate properly with Aquarius in the future.

Translator Assembly

Cable connection points

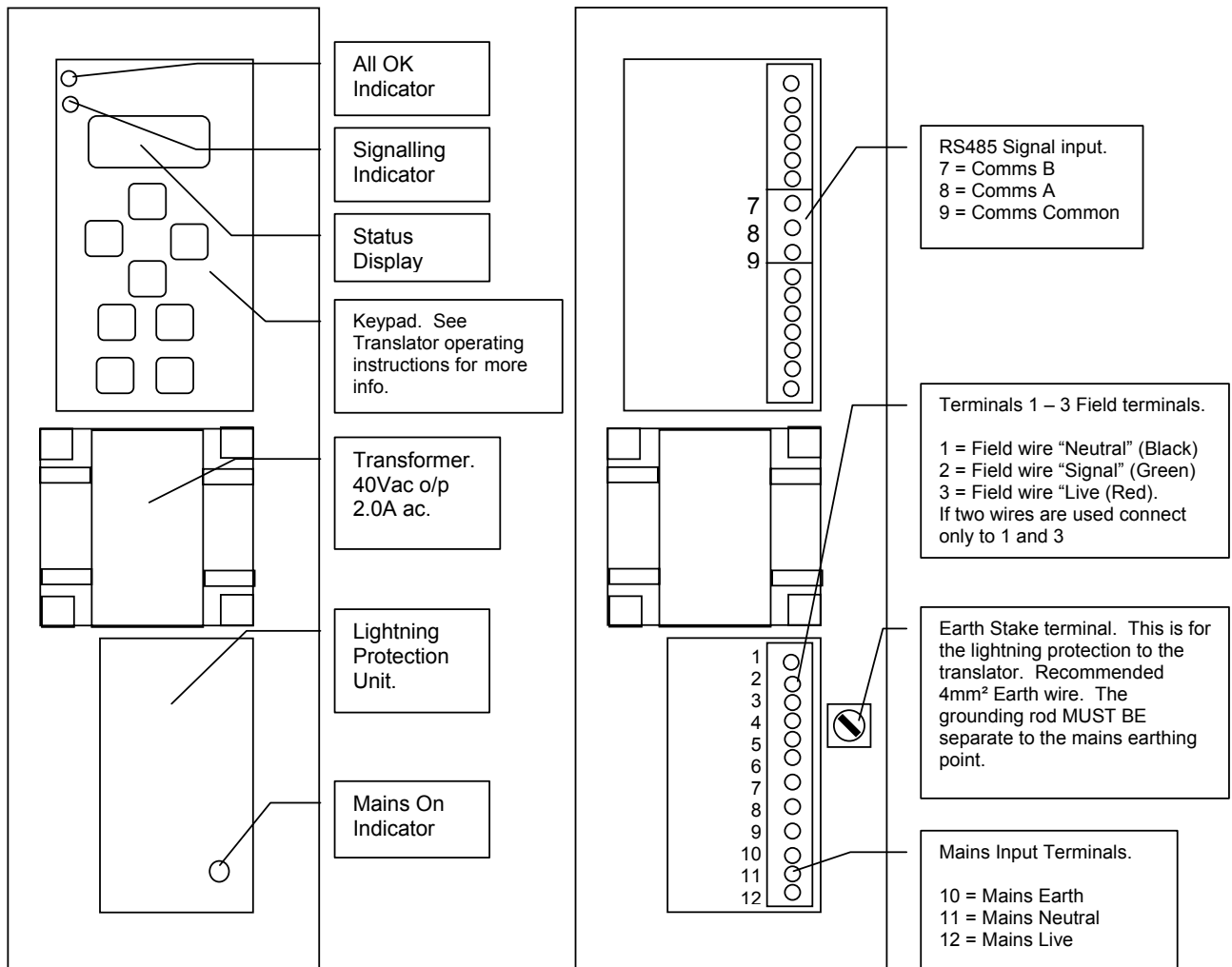

An RS232 to RS485 converter.

Optically Isolated RS232 – RS485 converter.

The translator uses a form of industrial communication called RS485. Most PC's use a communication called RS232. In order to convert from one to another there is a small converter called the RS232 – RS 485 converter. This unit is optically isolated to provide protection to the PC in the event of there being a surge or lightning strike on the communication cable.

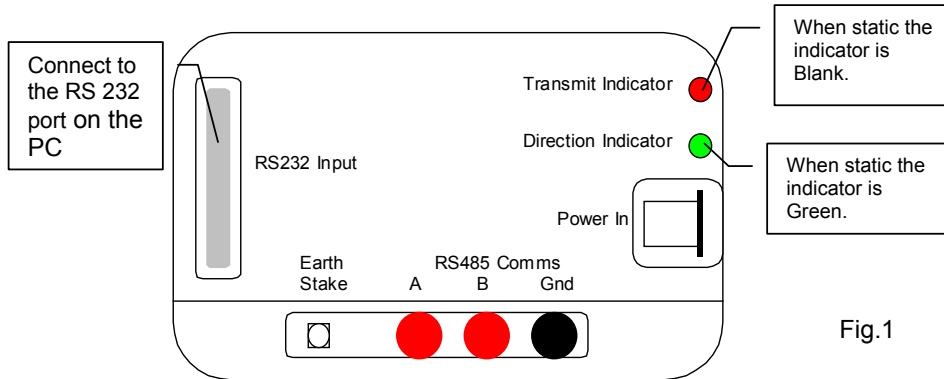

Fig.1

Connecting the converter to the translator is a communication cable. If this cable is fairly short (less than 200M) then it can be a simple 3 core cable of small size (typically 0.5mm²)

The Translators can be installed some distance away from the PC (up to several kilometres) providing that the correct 3 core cable is installed. This should be 1.5mm² - 2.5mm² 3 core armoured cable (depending on the distance) and is grounded at regular intervals (every 400 – 500M) making sure that all joints are properly bonded and potted.

Installation:

Hardware.

Mount the translators on the wall where the field wires can easily be connected (normally if more than one translator is supplied they will be mounted inside a steel cabinet).

Connect up the mains power supply. Each translator requires a 240Vac/110Vac 350mA/700mA.
Connections are:

Terminal No.	Connection
10	Mains earth (ground)
11	Mains Neutral
12	Mains live (hot)

Connect up the field wires.

Connect up the 3 core communications wire to the translators. Connections are:

Terminal No.	Connection
1	Field wire neutral (Black)
2	Field wires signal (Green)
3	Field wires Live (Red)
	Note: Signal only applicable to 3 wire systems

Connect up a grounding wire to the translators and connect this to a ground rod.. This MUST be separate to the mains earth point.

If the RS 232 to RS 485 converter is in a separate location to the Translators then there must be a grounding rod installed and connected to the converter.

Plug in the 25w D-connector to the converter and plug the 9 pin end into a spare port on the PC.

Security Key:

Supplied with the software is a security key (sometimes known as a dongle).

The security key prevents unauthorised use of the software on a machine that the system was not installed onto. It also prevents more than one user making use of the control system.

If the key is not connected the Aquarius software will behave as a demo software only.

Before the installation of the software takes place the key should be plugged into the parallel port of the computer. Generally this is the same plug point as the printer.

To connect it remove the printer lead from the back of the computer. Plug in the security key and tighten the screws. Plug the printer lead into the security key and tighten the screws.

Software:

If an upgrade is being installed it is strongly recommended that a copy of the database (C:\Program Files\Aquarius\Data\AquariusLive.mdb) is copied prior to upgrading. The old version of Aquarius should be fully removed before the new version is installed.

Insert the Aquarius Universal CD into the CD drive of the computer.

Click the mouse on the “Start” button on the task bar.

Click on the “Run” button

In the screen that appears click on “Browse” and find the drive that corresponds to the CD (usually “D”) on the computer.

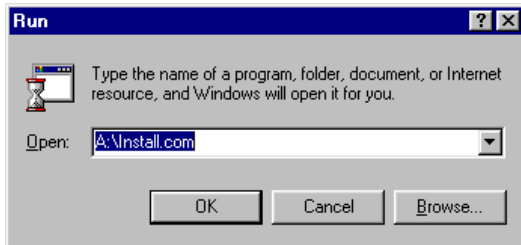

Select “SetupAquarius.exe”

Click on “open”.

This will then display the file “SetupAquarius” in the open window.

Click on “OK”.

The Program will now load onto the PC. Follow the on screen instructions when asked until the program has completed.

After Aquarius Universal has been installed a new screen will appear asking if the Microsoft Data Access Pack is to be installed. This program contains essential software required for the operation of Aquarius. The screen is as follows:

Click the large install button and again follow the on screen instructions.

When the screen with the “Complete/Custom Install” button appears click on the “Complete/install button”.

There are several displayed. Select all options (or click on the “select All” button) and then click on “Continue”.

The Data Access Pack will then be installed.

After reading the notes on the installation (not necessary, but only for information) Aquarius is ready for running.

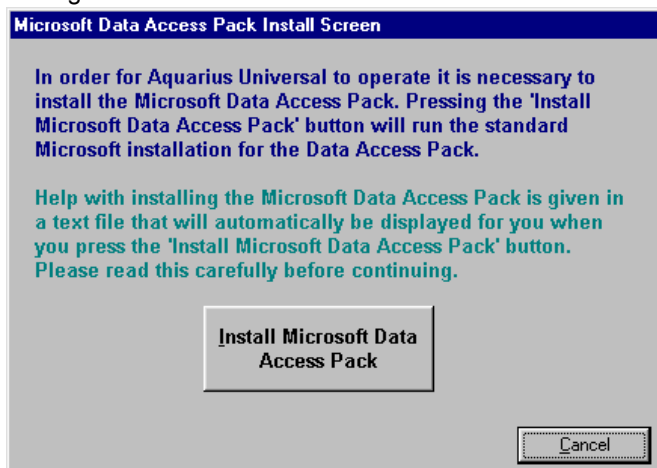

Aquarius Universal is made up of three programs as well as some optional add-on software.

Aquarius Universal is the main operating program. This is the software that allows the user to program the database, set up and edit new programs, schedule the programs, run diagnostic test and operate stations manually.

All the main database information is stored in a database called AquariusLive.mdb. The hardware data is stored in a database called AquariusHWLive.mdb. Both databases can be found in the directory C:\Program Files\Aquarius\Data. See Appendix C for more information.

When any data is entered it is stored in the AquariusLive.mdb database. Anytime data is modified, or programs are written or scheduled the resulting data is downloaded to another database called AquariusRunLive.mdb. This is the main operating database. It also is found in directory C:\Program Files\Aquarius\Data. This database is read by the second operating program **Aquarius Run**. Aquarius Run is the program that actually communicates with the translators. It takes all the data relating to the run times and start times that is stored in the database and at the allotted times turns valves on and off.

In order to prevent a program from not being run when it is due to be scheduled there is a watchdog program **Aquarius Watch** that monitors all the schedules and if a schedule is due to run and hasn't started because Aquarius Run is not active it will instruct AquariusRun to start.

NOTE: Aquarius Watch is no longer present in versions 2.1 and above.

The current add-on options that are available are the Remote control and the graphical interface. The Remote control option requires a radio modem interface and a radio handset. No other software is required. The Graphical interface requires a software key to make the option active. This is available from Logic Irrigation once the license for the option has been purchased.

Logic Aquarius Operation Manual

Windows Basics.

The Logic Aquarius Universal Program has been written to operate from within Microsoft Windows® 95, Windows® 98 and Windows® NT.

If this is the first time that Windows has been used or the operation of Windows or a mouse is unfamiliar then it is recommended that the program “Welcome” is run and follow the option labelled “Discover Windows 98”. This is a tutorial which helps to explain the basics of Windows. A copy of this program is included on the Aquarius CD.

Most operations can be carried out using the mouse that is connected to the PC.

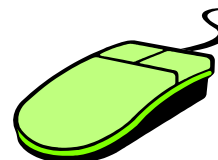
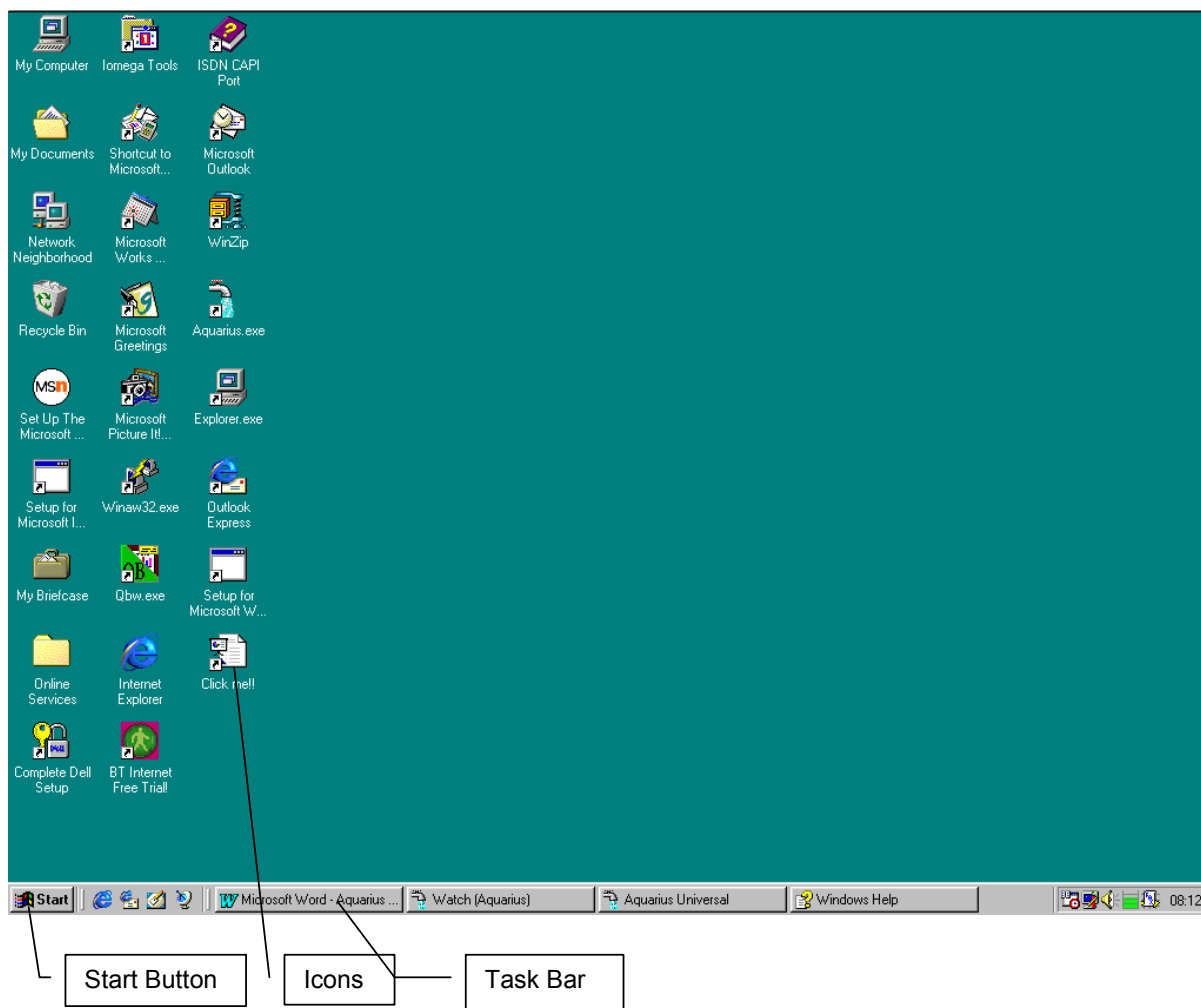

Fig 2: A typical two-button mouse.

Windows® uses a series of little pictures (commonly known as icons) to display which programs are available.



Many of these are displayed on the main screen area commonly known as the “desktop”.

Along the base of the desktop there is a bar called the task bar. The task bar shows which programs are currently running. By pointing the mouse and clicking once it is possible to select any of the programmes that are currently active. At the right hand end of the task bar is the start button.

To select and start a program:

- 1) Move the mouse pointer to the icon on the main screen and press the left-hand button once to highlight the icon. The text beneath the icon will change colour (the default colour is blue) to show that it has been selected.
- 2) To start (or load) the program place the mouse pointer onto the icon representing the program and click the left-hand button on the mouse twice rapidly (usually described as a “double click”).

The selected program will now start.

Starting The Aquarius Universal Program

The Aquarius Universal Program can be started by one of two ways.

Method 1: Using a short-cut icon on the Windows desktop

Point at the Aquarius Universal icon on the desktop (if installed). It will look something like this:

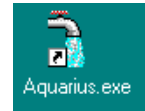

With the mouse pointer on the icon “double click” the left mouse button and the Aquarius Universal program will start.

Method 2: Using the Start button from the Windows taskbar.

Pointing the mouse at the start button on the task bar at the bottom of the screen and clicking once will bring up a list. One of the items labelled is “Programs”. Point the mouse at “Programs” and another list will appear to the right. Towards the top of this list is a menu item labelled “Aquarius Universal.” Pointing at this label will show another list. Point the mouse at the icon labelled “Aquarius Universal” and click the left button of the mouse. This will load Aquarius Universal.

Method 3: Automatically starting when Windows starts.

If there is a short cut set up in the start menu then Aquarius Universal will start as soon as the computer starts (or boots) up.

Windows Passwords:

It is important not to set up Windows® with a password when starting up. This will allow Aquarius to start up automatically in the event of a power cut and the computer restarting when the power returns.

Power Saving Features:

All power saving features for Windows MUST be disabled otherwise Aquarius will not operate properly.

The first screen to be seen is the ‘log on’ screen

Logging On:

Once Aquarius Universal has started use the mouse to point at the small drop down arrow by the **user name** box. Click the left-hand button of the mouse and a list of users will appear. From this list pick out your name or the default user (usually ‘Greenkeeper’ or Administrator’).

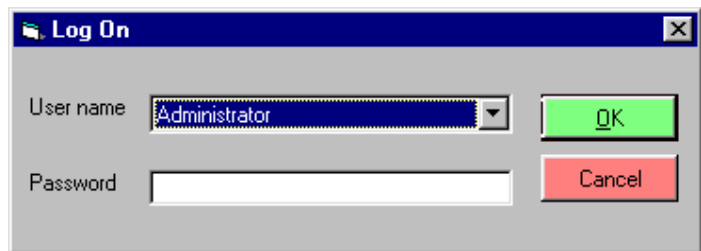

Next point the mouse into the password box and click the left-hand button. Type in the password for that user. **“Remember passwords are case sensitive”** (The default password is “password”).

Once the password has been entered either point at the “OK” button with the mouse and click the left-hand button or press the key marked “↵” on the keyboard.

The program will now load up and start the main Aquarius Universal program.

Aquarius Universal main screen.

The main screen comprises of two parts.

- 1) The main desk top with the menu bar and the status bar
- 2) The "Standard Activities screen" comprising of a series of large buttons designed to allow the user quick access to all major parts of the programs.

The main desktop looks like this:



The main
Menu Bar.

Status Bar

To select a menu option point the mouse at the menu title required and click the left button on the mouse. The menu will drop down a list of options.

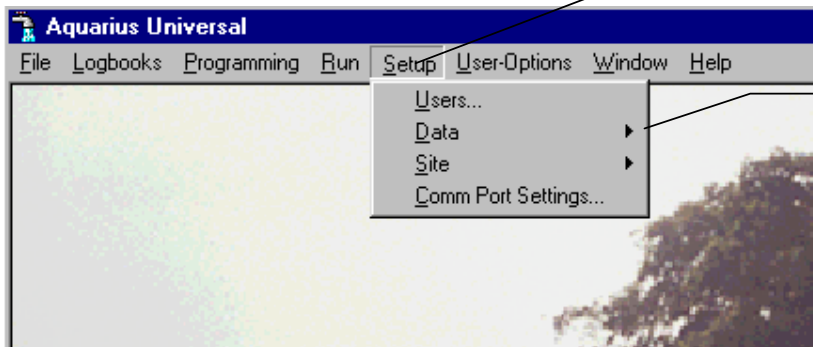

Click on the menu
item required.

Where there is an
arrow there are
further options
available

Where there are arrows pointing away from the menu there are more options available. Point the mouse at the option with the arrow and a new list will appear. To select an option point and click the left button on the menu item required. This will then load the appropriate part of the program.

There is more information about the menu options in the menu appendix (Appendix D) at the end of this manual.

The standard activities form

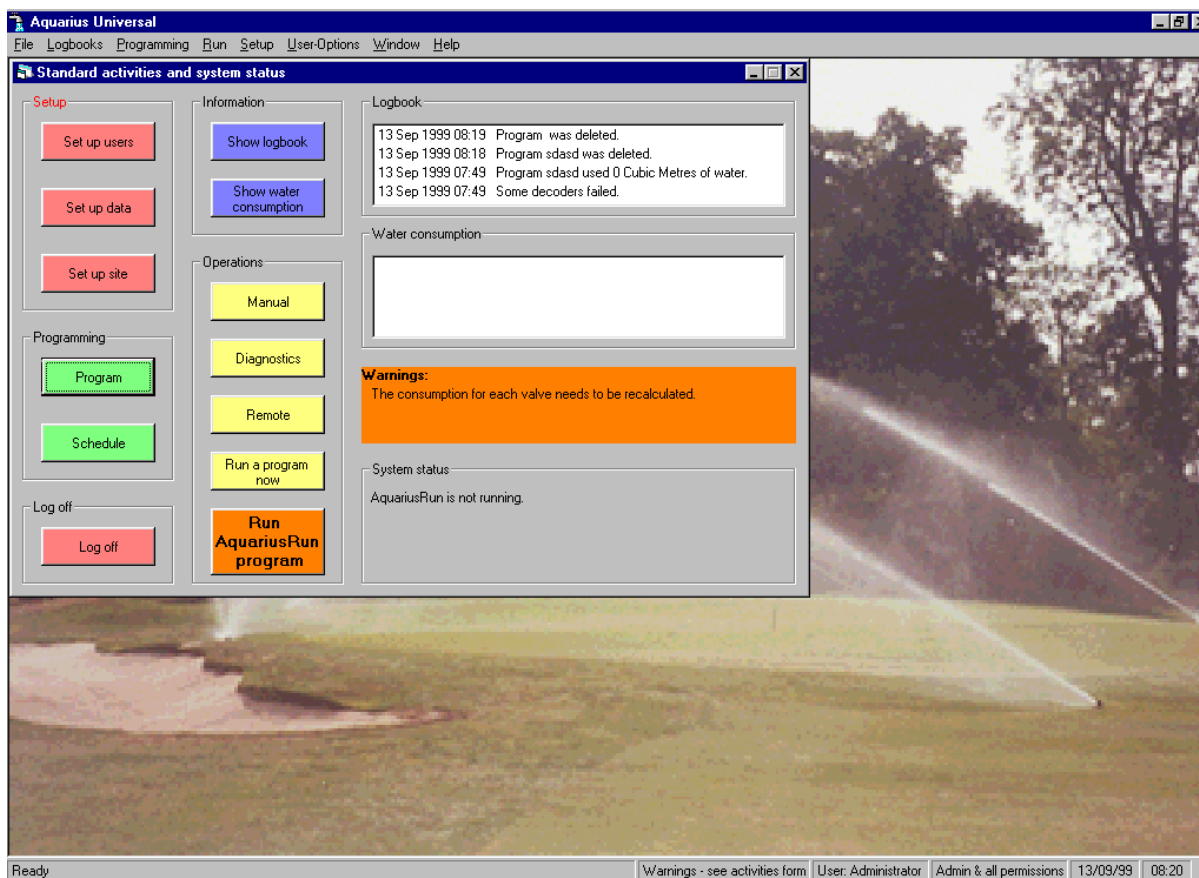

From the standard activities form all aspects of the Aquarius Universal can be accessed.

Below is a summary of each of the buttons and what their function is:

“Set up users”: Selecting this button allows new users to be added and all existing users permissions adjusted.

“Set up data”: Selecting this button allows the general data for the site to be created or edited.

“Set up site”: Selecting this button allows the data specific to this site to be created or edited.

“Program”: Selecting this button allows programs to be created and edited. All programs can be written either by time or by precipitation.

“Schedule”: Selecting this button allows schedules to be created and edited.

“Log Off”: Selecting this button will leave the Aquarius Universal program and wait for a new user to log on as the current user.

“Show Log Book”: Selecting this button allows the log book to be accessed and all entries viewed.

“Show Water Consumption ”: Selecting this button allows the water consumption logbook to be viewed.

“Manual”: Selecting this button allows the use of the manual operation of valves.

“Diagnostics”: Selecting this button allows a diagnostic program to be created and run.

“Remote”: Selecting this button allows the remote option to be activated.

“Run a program now”: Selecting this button allows a program to be started immediately.

“Run AquariusRun Program”: Selecting this button starts the Aquarius Run program. This program MUST be running for any control of the valves to take place.

Navigating a Form

Throughout the Aquarius Universal program forms are used to enter and store information as well as using the information to create programs and schedules.

A typical form looks like the one below:

When a row is selected a small arrow will point along the row. This arrow is visible to the left of the status column.

The screenshot shows a window titled "Valves" with search filters and a data table. The search filters include "Search for Course" (set to [All]), "Search for Hole" (set to [All]), "Search for controller zone" (set to [All]), and "Search for hydraulic zone" (set to [All]). The "Order by" dropdown is set to "Standard". A status indicator shows "236 valves shown out of a total of 236".

Status	Course name	Hole name	Valve location type	Valve location sub type	Valve location description	Zone name and wire segment	Decoder number	Decod.
	Course	Hole 1	Tee	All		1; segment a to b	11	TW/W
	Course	Hole 1	Fairway	1st in Middle		1; segment a to b	23	TW/W
	Course	Hole 1	Fairway	1st RHS		1; segment a to b	24	TW/W
	Course	Hole 1	Fairway	1st LHS		1; segment a to b	25	TW/W
	Course	Hole 1	Fairway	2nd RHS		1; segment a to b	26	TW/W
	Course	Hole 1	Fairway	2nd LHS		1; segment a to b	27	TW/W
	Course	Hole 1	Fairway	3rd RHS		1; segment a to b	28	TW/W
	Course	Hole 1	Fairway	3rd LHS		1; segment a to b	29	TW/W
	Course	Hole 1	Fairway	4th RHS		1; segment a to b	30	TW/W
	Course	Hole 1	Fairway	4th LHS		1; segment a to b	31	TW/W
	Course	Hole 1	Fairway	5th RHS		1; segment a to b	32	TW/W
	Course	Hole 1	Fairway	5th LHS		1; segment a to b	33	TW/W
	Course	Hole 1	Fairway	6th RHS		1; segment a to b	34	TW/W
	Course	Hole 1	Fairway	6th LHS		1; segment a to b	35	TW/W
	Course	Hole 1	Fairway	7th RHS		1; segment a to b	36	TW/W
	Course	Hole 1	Fairway	7th LHS		1; segment a to b	37	TW/W
	Course	Hole 1	Fairway	8th RHS		1; segment a to b	38	TW/W

The toolbar at the bottom contains the following buttons: "Insert below", "Copy row and insert below", "Delete row", "OK & edit sprinklers for selected valve", "OK", "Cancel", "Print", and "Help".

A general description of the various buttons

“Insert below”: Clicking on this button will add a new blank line into the form. The relevant information can be added ensuring that all mandatory fields are completed. “New” will appear in the status column on the left side of the form.

“Copy row and insert below”: This only appears in the valve form. When clicked on a copy of the row selected will be made immediately below. Certain fields will be left blank and will require filling in, other fields will need modifying in order to ensure that the information is unique to that entry. “New” will appear in the status column on the left side of the form.

“Delete row”: Clicking on this button will delete the selected row. “Deleted” will appear in the status column on the left side of the form. Only when an “OK” button is clicked on will the row actually be deleted.

“OK & goto”: Clicking on this button (the text will vary depending on the form) will update the information in the form and move to another form.

“OK”: Clicking on this button will update the information in the form and return to the “Standard Activities form”.

“Cancel”: Clicking on this button will cancel all changes (whether a line has been added or modified or a row has been deleted).

“Print”: Clicking on this button will bring up the print option screen. See Appendix E for more information.

“Help”: Clicking on this button will bring up the help screen for this form.

“Status”. This column shows what operation has been carried out on a selected row. The information displayed will be: “New” for a new entry, “Changed” for an entry that has been modified, “Deleted” for an entry that has been deleted.

Downloading information.

Whenever data in a form or a program is modified it is necessary to download the data into the AquariusRun database. Usually the following screen appears:

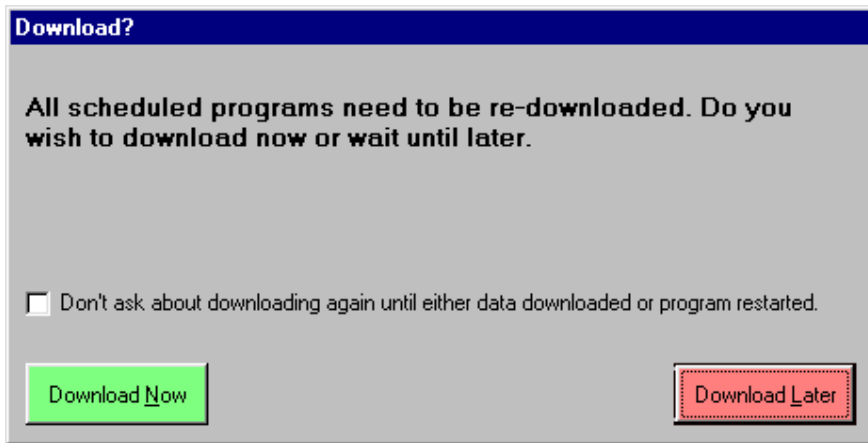

Download?

All scheduled programs need to be re-downloaded. Do you wish to download now or wait until later.

Don't ask about downloading again until either data downloaded or program restarted.

Download Now Download Later

If there is more data to be changed then click on the "Download Later" button. This screen will then disappear. If the "Don't ask....." box is ticked the screen will not reappear.

Once the modifications have been completed and the standard activities screen is in view again there will be some large orange buttons. These are the download buttons. Clicking on these will up date all program information.

Setting up the users.

To set up new users click on the “Set up users” button.

The “User Information” screen will appear.

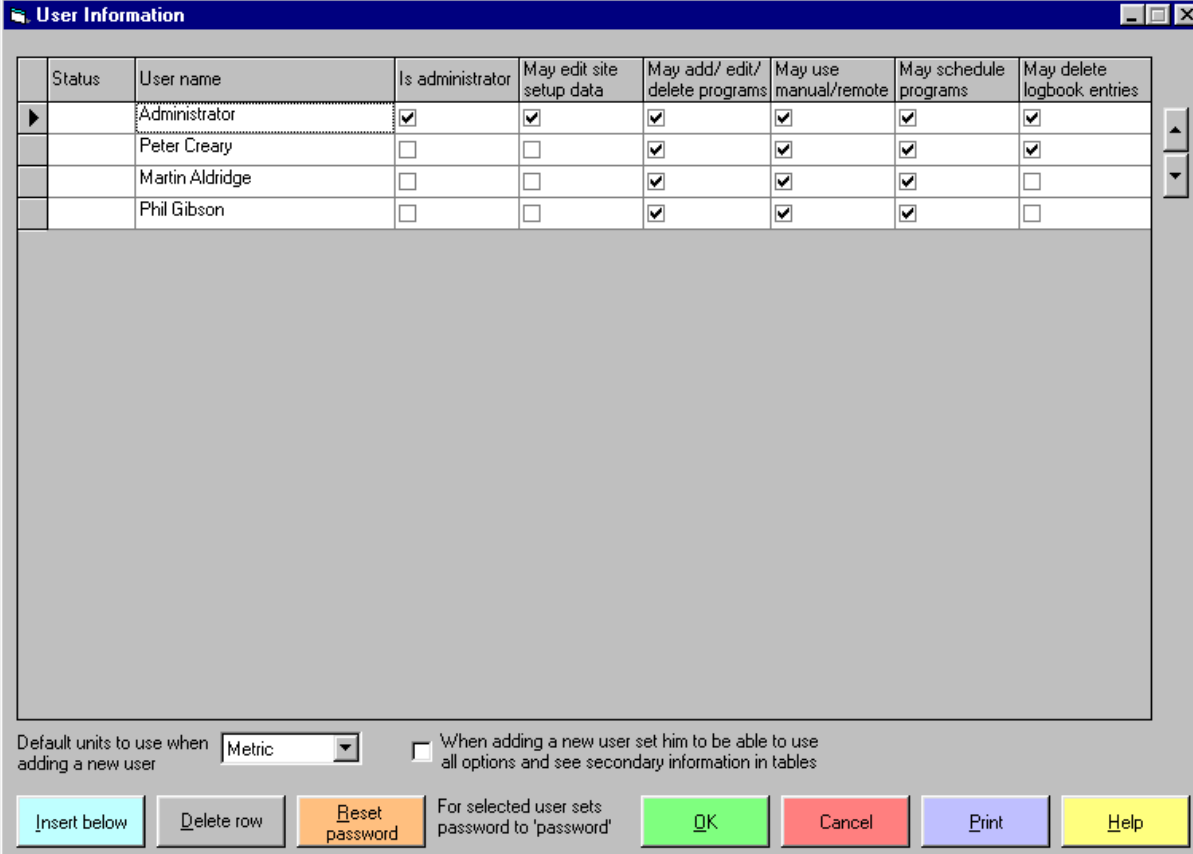

The screenshot shows a window titled "User Information" with a table of users and their permissions. The table has the following columns: Status, User name, Is administrator, May edit site setup data, May add/ edit/ delete programs, May use manual/remote, May schedule programs, and May delete logbook entries. The rows are: Administrator (checked for all), Peter Creary (checked for all except administrator), Martin Aldridge (checked for all except administrator), and Phil Gibson (checked for all except administrator). Below the table are several controls: a dropdown for "Default units to use when adding a new user" set to "Metric", a checkbox for "When adding a new user set him to be able to use all options and see secondary information in tables" (unchecked), and a row of buttons: "Insert below", "Delete row", "Reset password", "OK", "Cancel", "Print", and "Help".

Status	User name	Is administrator	May edit site setup data	May add/ edit/ delete programs	May use manual/remote	May schedule programs	May delete logbook entries
	Administrator	<input checked="" type="checkbox"/>	<input checked="" type="checkbox"/>	<input checked="" type="checkbox"/>	<input checked="" type="checkbox"/>	<input checked="" type="checkbox"/>	<input checked="" type="checkbox"/>
	Peter Creary	<input type="checkbox"/>	<input type="checkbox"/>	<input checked="" type="checkbox"/>	<input checked="" type="checkbox"/>	<input checked="" type="checkbox"/>	<input checked="" type="checkbox"/>
	Martin Aldridge	<input type="checkbox"/>	<input type="checkbox"/>	<input checked="" type="checkbox"/>	<input checked="" type="checkbox"/>	<input checked="" type="checkbox"/>	<input type="checkbox"/>
	Phil Gibson	<input type="checkbox"/>	<input type="checkbox"/>	<input checked="" type="checkbox"/>	<input checked="" type="checkbox"/>	<input checked="" type="checkbox"/>	<input type="checkbox"/>

Default units to use when adding a new user: When adding a new user set him to be able to use all options and see secondary information in tables

For selected user sets password to 'password'

An administrator is the only person who can add or change users permissions. There can be more than one administrator.

Setting up the Database

Before Aquarius can be used a database must be set up for the individual site. The set up procedure is very straight forward. By clicking on the set up database button on the standard activities form it is possible to follow through the complete set up in a progressive manner.

It is recommended that copies of the forms attached to the end of this manual (**Appendix E**) be used to collect all the necessary information before proceeding with the database set up.

There are two parts to the database, the general database and the site database.

The general database

This part of the database remains the same for all sites or courses. There are seven database forms in this section.

They are

- i) District (or courses)
- ii) Areas (or holes)
- iii) Valve location type (Station types e.g.: Greens, Tees etc)
- iv) Valve location sub type (A sub group of the station type e.g.: Back left, Back right etc).
- v) Valve type (Make of valve and its size and closing time)
- vi) Sprinkler type (includes all the sprinkler performances for all sprinklers)
- vii) Defaults data (the defaults used when creating a new station)

Both the District and Area forms can be labelled with what ever label is suitable for the individual site. If the site is a landscape site these labels could be Towns and Apartment complexes etc, or if it was horticulture they could be Nurseries and Greenhouses. To change these labels refer to **Appendix A** for more details.

To set up the general database click on the "Set up Database" button on the standard activities form.

The first form to load up is the Districts database form.

Districts form

Status	District name	District description	Unique remote 2 digit code
▶	Course	The complete course	01

Buttons at the bottom: Insert below, Delete row, OK & goto Area data, OK, Cancel, Print, Help

To enter the District name click in the District name field and type in the new name. If required enter a further description in the District description field and finally enter in the unique remote code. This must be entered before moving on even if there is no remote control attached to the system.

The “District name” and “Unique remote 2 digit code” are mandatory the description is for additional information only.

There is no limit to the number of Districts that can be entered. However, it is worth remembering that if the database is large then it will be necessary to use a more powerful machine than the one recommended as the minimum specification.

Once all the districts have been entered click on the “OK & goto Area data” button.

The new screen will now show the list of the areas currently set up.

Area form:

Status	Area name	Area description	Unique remote 2 digit code
▶	Hole 1	1	01
	Hole 2	2	02
	Hole 3	3	03
	Hole 4	4	04
	Hole 5	5	05
	Hole 6	6	06
	Hole 7	7	07
	Hole 8	8	08
	Hole 9	9	09
	Hole 10	10	10
	Hole 11	11	11
	Hole 12	12	12
	Hole 13	13	13
	Hole 14	14	14
	Hole 15	15	15
	Hole 16	16	16
	Hole 17	17	17
	Hole 18	18	18

Buttons: Insert below, Delete row, OK & goto valve location type, OK, Cancel, Print, Help

To enter the Area name click in the Area name field and type in the new name. If required enter a further description in the Area description field and finally enter in the unique remote code. This must be entered before moving on even if there is no remote control attached to the system.

The “Area name” and “Unique remote 2 digit code” are mandatory the description is for additional information only.

There is no limit to the number of Areas that can be entered. However, it is worth remembering that if the database is large then it will be necessary to use a more powerful machine than the one recommended as the minimum specification.

Once all the Areas have been entered click on the “OK & goto valve location type” button.

The new screen will now show the list of the valve location types currently set up.

Valve location type form:

Status	Valve location type name	Valve location type description	Unique remote 2 digit code
▶	Lawns	Lawn Areas	01
	Borders	Borders	02
	Shrubs	Shrubs	03
	Drip	Drip lines	04

Buttons: Insert below, Delete row, OK & goto valve location sub type, OK, Cancel, Print, Help

The valve location type is the basic station description. For example, if the system is a golf course the “valve location types” would typically be “Green”, “Tee”, “Approach” or “Fairway”. It is not necessary to put Green Back Left etc as the further breakdown of each station type comes with the next screen “valve location sub type”.

To enter the valve location type name click in the valve location type name field and type in the new valve location type name. If required enter a further description in the valve location type description field and finally enter in the unique remote code. This must be entered before moving on even if there is no remote control attached to the system. It is recommended that the remote codes are set in order of preference. E.g.: If greens are the highest priority then set the valve location type called green (if there is one) to remote code 01 and so on.

The “Valve location type name” and “Unique remote 2 digit code” are mandatory the description is for additional information only.

There is no limit to the number of valve location types that can be entered. However, it is worth remembering that if the database is large then it will be necessary to use a more powerful machine than the one recommended as the minimum specification.

Once all the valve location types have been entered click on the “OK & goto valve location sub type” button.

The new screen will now show the list of the valve location sub types currently set up.

Valve location su+b type form:

Status	Valve location sub type name	Valve location sub type description	Unique remote 2 digit code
	All	All	01
	Left	Left	02
	Right	Right	03
	Front	Front	04
	Back	Back	05
	Main		06
	Main 1		14
	Main 2		15
	Ladies		45
▶	Championship		46
	1		40
	2		41
	3		42
	3 Left		43
	3 Right		44
	Middle		07
	Drive		08
	Bushes		09
	Fence		10
	House		11
	Pool		12
	Club Pit		13

The valve location sub type is the basic station description. For example, if the system is a golf course the “valve location sub types” would typically be “Left” or “Right” (for a Green), “Championship” or “Main” (for a Tee), “All” (for an Approach) or “A left” or “A Right” (for Fairway).

To enter the valve location sub type name click in the valve location sub type name field and type in the new valve location sub type name. If required enter a further description in the valve location sub type description field and finally enter in the unique remote code. This must be entered before moving on even if there is no remote control attached to the system.

The “Valve location sub type name” and “Unique remote 2 digit code” are mandatory the description is for additional information only.

There is no limit to the number of valve location sub types that can be entered. However, it is worth remembering that if the database is large then it will be necessary to use a more powerful machine than the one recommended as the minimum specification.

Once all the valve location sub types have been entered click on the “OK & goto valve type” button.

The new screen will now show the list of the valve types currently available.

Valve type form:

Status	Valve Manufacturer	Valve Model	Size	Closing time
	Weathermatic	11024FCR-15	1.5"	30
	Weathermatic	8024BCR-15	1.5"	30
	Weathermatic	8024BCR-12	1.25"	20

The default valve type is shown in blue

Buttons: Insert below, Delete row, OK & goto sprinkler type, OK, Cancel, Print, Help

Because modern control systems electrically operate the solenoids very quickly it is possible for several valves to be on simultaneously. This can happen because a valve instructed to switch off can take several seconds to close while a valve instructed to switch on will activate immediately. If this happens it could effect the hydraulics of the system and could possibly cause the pumps to cut out due to low pressure.

To avoid the possibility of this happening Aquarius Universal has a default 5 second delay between one valve being de-activated and another one being activated. If this delay is not sufficient it can be extended by entering a longer time period (in seconds) in the column marked as closing time. For example: if there are some 2" valves installed on a site these can take up to 90 seconds to actually shut. Therefore by entering 90 seconds into the "Closing time" column against the 2" valve will ensure that Aquarius Universal will not turn another valve on until the 90 seconds has elapsed.

All fields are mandatory therefore the "Valve Manufacturer", "Valve Model", "Size" and "Closing time must be entered.

There is no limit to the number of valve types that can be entered. However, it is worth remembering that if the database is large then it will be necessary to use a more powerful machine than the one recommended as the minimum specification.

Once all the valve types have been entered click on the "OK & goto sprinkler type" button.

The new screen will now show the list of the sprinkler types currently available.

Sprinkler type form:

The screenshot shows a window titled "Sprinkler Type" with a table containing the following data:

Status	Sprinkler manufacturer	Sprinkler model	Sprinkler nozzle	Rotation speed	Default arc
▶	Logic	L210	15B	1	180
	Logic	L210	16B	1	180
	Logic	L210	17B	1	180
	Logic	L300	15C x 11A	1.5	360
	Logic	L300	16C x 11A	1.5	360
	Logic	L300	18C x 12A	1.5	360
	Logic	L300	20C x 12A	1.5	360
	Logic	L300	22C x 12A	1.5	360
	Logic	L300	24C x 12A	1.5	360
	Rainbird Eagle	700	14	4	360
	Weathermatic	PK50 AF	10	2	360
	Rainbird Eagle	700	16	4	360
	Weathermatic	PK70 AF	14	3	360
	Rainbird Eagle	700	18	4	360
	Weathermatic	PK70 PF	16	2	180
	Hunter	I31	Orange 7	4	360
	Rainbird Eagle	700	20	4	360
	Hunter	I31	Lt Green 10	4	360
	Rainbird Eagle	700	22	4	360
	Rainbird Eagle	700	24	4	360
	Toro	650	54	5	180

Below the table, a note states: "The default sprinkler type is shown in blue". At the bottom of the window are several buttons: "Insert below", "Delete row", "OK & edit pressures for selected sprinkler", "OK & goto defaults data", "OK", "Cancel", "Print", and "Help".

All fields are mandatory therefore the “Sprinkler manufacturer”, “Sprinkler model”, “Sprinkler nozzle”, “Rotation speed” and “Default arc” must be entered.

There is no limit to the number of sprinkler types that can be entered. However, it is worth remembering that if the database is large then it will be necessary to use a more powerful machine than the one recommended as the minimum specification.

For each sprinkler type entered the performance for that sprinkler must be set up. To enter the performance figures click on the “OK & edit pressures for selected sprinkler” button.

The screen will now show the sprinkler pressure form.

The sprinkler pressure form:

Status	Pressure (Bar)	Coverage (Metres)	Flow (Cubic Metres per Hour)
▶	6.3	17.1	3.35
	5.6	16.8	3.3
	4.9	16.3	2.92
	4.2	16	2.68
	3.5	15.6	2.45

Buttons: Insert below, Delete row, OK, Cancel, Help

The operating pressure ranges for the selected sprinkler must be added (use the manufacturers figures where possible) and for each pressure the coverage and performance must also be entered.

Once all the performance for a specific nozzle has been added click on “OK” to save the information and return to the main Sprinkler form.

If the units that are displayed are not the desired units the it is possible to change the units. See **Appendix B** for more information.

Once all the performance data has been entered click on the “OK” button to return to the sprinkler form.

After all the sprinkler data has been entered click on “OK & goto defaults” button.

The new screen will now show the list of the defaults currently set up.

The Defaults form:

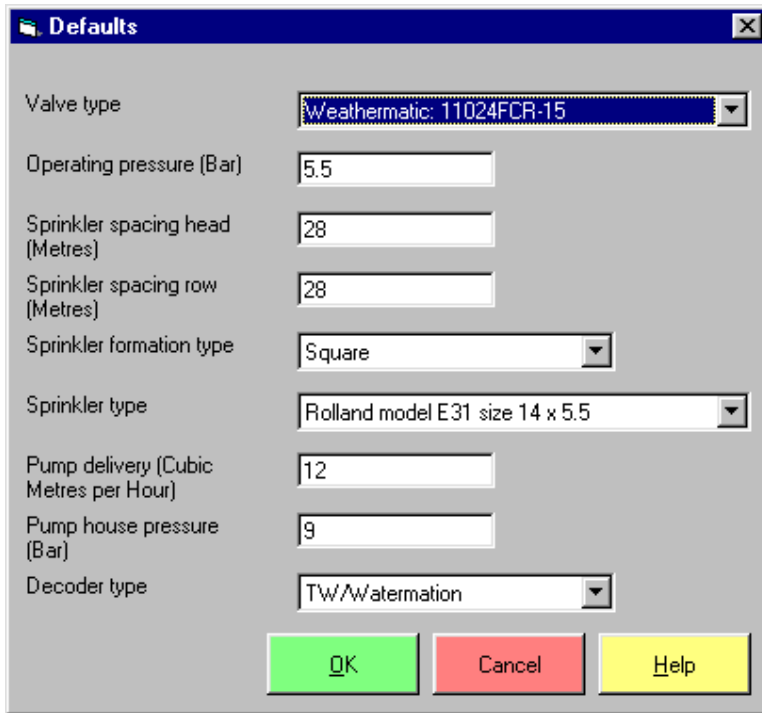

Valve type	Weathermatic: 11024FCR-15
Operating pressure (Bar)	5.5
Sprinkler spacing head (Metres)	28
Sprinkler spacing row (Metres)	28
Sprinkler formation type	Square
Sprinkler type	Rolland model E31 size 14 x 5.5
Pump delivery (Cubic Metres per Hour)	12
Pump house pressure (Bar)	9
Decoder type	TW/Watermatation

OK Cancel Help

Whenever a new station is created many of the standard items that have to be entered can be automatically added by setting the defaults with all the necessary information.

Every station has a valve. Set the valve type to the type that is most commonly used.

Set the operating pressure to the design pressure for the group of stations being created.

Set the spacing and formation to the typical spacing for the sprinklers installed.

Choose the sprinkler type commonly used.

Set the pump details and finally select the decoder type.

Generally if the defaults are set for a specific type of station (e.g.: Greens), create all the stations of this particular type and then change the defaults to a new set to create another group of stations (e.g.: Tees).

Once all the defaults have been set click on the "OK" button to return to the "Standard Activities form"

The site database

This part of the database is specific to the site that Aquarius is installed on. There are four main database forms in this section.

- They are
- i) Pump Houses
 - ii) Hydraulic zones
 - iii) Controller zones
 - iv) Valves

From the standard activities form click on the “Set up site” button.

The Pump Houses form appears.

Pump House:

Status	Pump House Name	Description	Pressure (Bar)
	Main pump house	The main pump house	9

Buttons: Insert below, Delete row, OK & edit pumps for selected pump house, OK & goto hydraulic zone, OK, Cancel, Print, Help

To enter the Pump House name click in the Pump House name field and type in the new Pump House name. If required enter a further description in the Pump House description field and finally enter the design output pressure for this pump house.

The “Pump House name” and “Pressure” are mandatory the description is for additional information only.

There is no limit to the number of Pump Houses that can be entered. However it is worth remembering that if the database is large then it will be necessary to use a more powerful machine than the one recommended as the minimum specification.

Once all the Pump Houses have been entered click on the “OK & edit pumps for pump houses” button.

The new screen will now show the list of the pumps entered for the selected pump house.

Pumps for a specific Pump House

Status	Pump Name	Description	Delivery (Cubic Metres per Hour)
▶	1	Mains	12
	2	Mains	12
	3	Mains	12
	4	Mains	12

Buttons: Insert below, Delete row, OK, Cancel, Help

For every pump house there must be at least one pump connected.

By default a new pump will have been added based on the information entered in the defaults form.

To enter the Pump name click in the Pump name field and type in the new Pump name. If required enter a further description in the Pump description field and finally enter the design output delivery for this pump.

The “Pump name” and “Delivery” are mandatory the description is for additional information only.

There are no limits to the number of Pumps that can be entered. However it is worth remembering that if the database is large then it will be necessary to use a more powerful machine than the one recommended as the minimum specification.

Once all the Pumps have been entered click on the “OK” button.

The screen will return to the Pump Houses form. If there are no more pumps or pump houses to be added click on the “OK & goto hydraulic zone” button.

The new screen will now show the Hydraulic zone form.

Hydraulic zone

Status	Hydraulic zone name	Description	Capacity (Litres per Minute)	Pump house
▶	1	Default	350	Main pump house
	2		350	Main pump house
	3		350	Main pump house
	4		350	Main pump house

Buttons: Insert below, Delete row, OK & edit pipe runs for selected hyd zone, OK & goto controller zone, OK, Cancel, Print, Help

Every system has a number of hydraulic zones.

To enter the Hydraulic zone name click in the Hydraulic zone name field and type in the new Hydraulic zone name. If required enter a further description in the Hydraulic zones description field. Enter the design flow for the Hydraulic zone and finally select which pump house the hydraulic zone is fed from.

The “Hydraulic zone ” and “Capacity” and “Pump house” are mandatory the description is for additional information only.

There are no limits to the number of Hydraulic zones that can be entered. However it is worth remembering that if the database is large then it will be necessary to use a more powerful machine than the one recommended as the minimum specification.

Once all the Hydraulic zones have been entered click on the “OK & edit pipe runs for selected hyd zone” button.

The new screen will now show the list of the pipe nodes for the selected hydraulic zone.

Pipe runs for Hydraulic Zone

Status	Pipe start point name	Pipe end point name	Pipe size	Pressure rating
▶	a	b	63mm	10 bar

Buttons: Insert below, Delete row, OK, Cancel, Help

If the Graphical interface is to be used it is necessary to enter in all the mainline pipe network into the database. Every hydraulic zone has a number of pipe nodes. To enter in the pipe nodes it is first necessary to lay out the nodes onto a drawing and having worked out the network enter this information into the pipe database. For example there may be twenty nodes in a specific hydraulic zone. These would be listed as:

Pipe start point name	Pipe end point name	Pipe size	Pressure rating
1	2	63mm	10
2	3	63mm	10
2	4	50mm	10
3	4	63mm	10
4	5	90mm	10
4	8	90mm	10

Once all the pipe nodes for the first hydraulic zone have been entered the pipe nodes for the remaining hydraulic zones would be entered ready for the graphics.

Every pipe must be given a size and pressure rating. These are found by clicking in the relevant box and clicking on the drop down list that appears. Both metric and imperial pipe sizes and pressure ratings are listed.

All fields are mandatory.

There are no limits to the number of pipe nodes that can be entered and the more entered the more accurate the drawing will be. It is worth remembering, however, that if the database is large then it will be necessary to use a more powerful machine than the one recommended as the minimum specification.

Once all the pipe nodes have been entered click on the "OK" button to return to the hydraulic zone form.

The screen will return to the Hydraulic Zone form. If there are no more hydraulic zones or pipe nodes to be added click on the “OK & goto controller zone” button.

The new screen will now show the Controller Zone form.

Controller Zone

Status	Zone name	Zone description	Controller address	Max number of decoders
▶	1	Zone 1	0	99
	2	Zone 2	1	99
	3	Zone 3	2	99
	4	Zone 4	3	99

Every system has a number of electrical (or controller) zones.

To enter the controller zone name click in the controller zone name field and type in the new controller zone name. If required enter a further description in the controller zones description field. Enter the controller address for the controller zone and finally select how many decoders are to be attached to this zone. This figure is for information only. It is worth noting that it is possible to mix decoder types on a system by having each interface (or zone) set up to operate different decoders.

To be clear as to the number of decoders attached to the controller the maximum number each type is as follows:

Decoder type	Max no /cable	Max active /cable	Notes
Watermation Mk1	97	1	
Watermation Mk2	-----	-----	Not supported
Tonick TW/WM	127	4	Can mix with Watermation Mk1
Wright Rain Mk1 & 2	255	4	Same as Primetime
Wright Rain Mk3	511	4	Watch the power drain
CIC 1 Or 4	99	1	
CIC+	198	2	1 in zone 1 and 1 in zone 2
Robydome Mk1 & 2	255	4	Same as Wright Rain
Robydome Mk3	511	4	Watch the power drain
Primetime	255	4	Same as Wright Rain
TORO	99	4	

The controller address is set by the cable number set in the translator. The controller address and the translator cable number MUST BE THE SAME otherwise the software will not be able to communicate with the translator.

The “controller zone”, “Controller address” and “Max number of decoders” are mandatory the description is for additional information only.

The maximum number of controller zones that can be entered is 32.

Once all the controller zones have been entered click on the “OK & edit wire runs for selected zone”.

The new screen will now show the list of the cable nodes for the selected controller zone.

Pipe runs for Hydraulic Zone

Status	Wire start point name	Wire end point name
▶	a	b

If the Graphical interface is to be used it is necessary to enter in all the cable network into the database. Every controller zone has a number of cable nodes. To enter in the cable nodes it is first necessary to lay out the nodes onto a drawing and having worked out the network enter this information into the cable database. For example there may be twenty nodes in a specific electrical zone. These would be listed as:

Wire start point name	Wire end point name
1	2
2	3
2	4
3	4
4	5
4	8

Once all the cable nodes for the first controller zone have been entered the cable nodes for the remaining controller zones would be entered ready for the graphics.

All fields are mandatory.

There are no limits to the number of cable nodes that can be entered and the more entered the more accurate the drawing will be. It is worth remembering, however, that if the database is large then it will be necessary to use a more powerful machine than the one recommended as the minimum specification.

Once all the cable nodes have been entered click on the "OK" button to return to the controller zone form.

The screen will return to the Controller Zone form. If there are no more controller zones or cable nodes to be added click on the "OK & goto valve" button.

The new screen will now show the Valves form.

Valves

The screenshot shows a software window titled "Valves". At the top, there are four search filters: "Search for Course" (set to [All]), "Search for Hole" (set to [All]), "Search for controller zone" (set to [All]), and "Search for hydraulic zone" (set to [All]). An "Order by" dropdown is set to "Standard". A status bar indicates "236 valves shown out of a total of 236".

Status	Course name	Hole name	Valve location type	Valve location sub type	Valve location description	Zone name and wire segment	Decoder number	Decod.
	Course	Hole 1	Tee	All		1: segment a to b	11	TW/W
	Course	Hole 1	Fairway	1st in Middle		1: segment a to b	23	TW/W
	Course	Hole 1	Fairway	1st RHS		1: segment a to b	24	TW/W
	Course	Hole 1	Fairway	1st LHS		1: segment a to b	25	TW/W
	Course	Hole 1	Fairway	2nd RHS		1: segment a to b	26	TW/W
	Course	Hole 1	Fairway	2nd LHS		1: segment a to b	27	TW/W
	Course	Hole 1	Fairway	3rd RHS		1: segment a to b	28	TW/W
	Course	Hole 1	Fairway	3rd LHS		1: segment a to b	29	TW/W
	Course	Hole 1	Fairway	4th RHS		1: segment a to b	30	TW/W
	Course	Hole 1	Fairway	4th LHS		1: segment a to b	31	TW/W
	Course	Hole 1	Fairway	5th RHS		1: segment a to b	32	TW/W
	Course	Hole 1	Fairway	5th LHS		1: segment a to b	33	TW/W
	Course	Hole 1	Fairway	6th RHS		1: segment a to b	34	TW/W
	Course	Hole 1	Fairway	6th LHS		1: segment a to b	35	TW/W
	Course	Hole 1	Fairway	7th RHS		1: segment a to b	36	TW/W
	Course	Hole 1	Fairway	7th LHS		1: segment a to b	37	TW/W
	Course	Hole 1	Fairway	8th RHS		1: segment a to b	38	TW/W

At the bottom of the window, there is a toolbar with the following buttons: "Insert below", "Copy row and insert below", "Delete row", "OK & edit sprinklers for selected valve", "OK", "Cancel", "Print", and "Help".

The valves form is where all the details about individual stations are brought together and entered. It is important to remember that all valves (stations) must be unique, i.e.: Only one valve can be in Course 1, Hole 1, Green, All, Zone 1, Decoder number 1.

It is important to ensure that all the information is available before starting to fill this form. Some information is mandatory and some is not. Where there are several choices available within a field a small arrow appears. Clicking on the arrow produces a drop down menu of the choices that were entered in when setting up the database.

A recommendation is to plan to input all the valves of a specific type first, e.g.: Enter all the greens valves in first. This allows the defaults to be set up for all the sprinklers, and spacing etc so that little modifications to the settings need to be made.

Description of the Valve Form fields:

The following is a description of the fields that are in the form and which are mandatory and which are not.

Field	Description	Mandatory	Normally hidden	Currently available
Course (District) Name	This is the course (district) that the valve is located in. The information for this is entered in the Data_Setup_District (Course) form	Yes	No	Yes
Hole (Area) Name	This is the hole (area) that the valve is located in. The information for this is entered in the Data_Setup_Area (Hole) form	Yes	No	Yes
Valve Location Type	This is the specific station type (e.g.: Green, Tee etc). The information for this is entered in the Data_Setup_Valve Location Type form	Yes	No	Yes
Valve Location Sub type	This is the specific station type (e.g.: Left, Right, Front, Back etc). The information for this is entered in the Data_Setup_Valve Location Sub Type form	Yes	No	Yes
Valve Location Description	This field is just for additional information about the station.	No	No	Yes
Zone name and wire segment	This list gives the zone number and a choice of wire segments for that zone. The selection of the wire segments is particularly important if the graphics are used.	Yes	No	Yes
Decoder number	Each valve has a decoder number. This number must be unique for each zone (i.e.: there cannot be two number 1 decoders on the same zone).	Yes	No	Yes
Decoder Type	Select from the list which decoder type is installed with the valve. For each zone there will be only one type of decoder installed. It is possible to have one make of decoder on one zone and a different make on another zone. The only exception is the Watermation Mk1. If these are installed it must be selected in this field	Yes	No	Yes
Load Factor	Each electrical zone can have up to 4 solenoids energised at one time.** The default load factor is always 1. To restrict the number of coils that can be energised at once change this number to a higher load factor. This will restrict the number of coils that can be energised at once. If there are either two coils or two decoders installed with the same number the load factor must be increased.	Yes	Yes	Yes
Hydraulic zone name and pipe segment	This list gives the hydraulic zone number and a choice of pipe segments for that zone. The selection of the pipe segments is particularly important if the graphics are used.	Yes	No	Yes
Hydraulic flow %	In some cases the valve location may be at a higher elevation than the rest and because the system is a retro-fit the hydraulics may be a problem if this valve and another nearby operate together. The hydraulic flow calculation can be fooled into thinking that the flow to this valve is higher than it really is by increasing the hydraulic flow %. This new figure will be used to calculate the flow of the valve for the purpose of the flow management but the actual flow will be logged in the log books.	Yes	Yes	Yes
Operating pressure	This is pressure at the valve that the flow for the sprinklers is based on.	Yes	No	Yes
Number of sprinklers	The number of sprinklers (or outlets) connected to the valve.	Yes	No	Yes
Enter precipitation manually	If the spacing of the sprinklers is not consistent or there is a mixture of sprinklers (or outlets) attached to the valve the precipitation cannot be calculated automatically. Therefore an estimate (or educated guess) or figures from CIT Hyper-space program will have to be used to set the precipitation rate for the valve. The tick box will have to be ticked. At present all precipitation has to be entered manually.	Yes	No	Yes

Sprinkler formation type	This sets the formation of the sprinklers connected to the valve. Whether they are Square, Triangular, In-line etc.	Yes	Yes	Yes
Head Spacing	The spacing between the heads.	Yes	Yes	Yes
Row Spacing	The spacing between the rows.	Yes	Yes	Yes
Precipitation Rate	The precipitation is calculated from the above figures or entered in manually if the "Enter Precipitation Manually" box is ticked.	Yes	No	Yes/No
Consumption	This calculated from the number of sprinklers connected based on the operating pressure entered.	Yes	No	Yes
Valve	This is selected from the list of valve types available. It is important that the correct valve is selected if there are different sizes used as the closing times for each valve is different.	Yes	Yes	Yes
Priority	The priority for each valve is set here. The lower the priority number the higher the priority of the valve.	Yes	Yes	Yes
Infiltration Rate	This is based on the figure obtained from tests on the area irrigated by this valve. At present not available.	Yes	Yes	No
Min repeat gap	This is based on what the infiltration rate. At present not available.	Yes	Yes	No
Max run time	This is intended to act as a reminder to the user that the maximum run time designed for this system has been exceeded. At present not available.	Yes	Yes	No
Constraint type	It is desirable to prevent a valve from operating before or after certain times of the day (or night). Selecting the constraint type to "Must water before, Must water after" etc will prevent this valve from operating until the constraint has been met. At present not available.	Yes	Yes	No
Constraint time	This is the time that the constraint type will use as a basis for allowing the valve to activate. At present not available.	Yes	Yes	No

** The number of solenoids that can be energised is dependant on the cable size, cable length and the number of decoders attached to the zone.

To add a new valve click on the "Insert below" button and enter the new valve.

If the valve above already has the same basic information as the new valve by clicking on the "Copy row and insert below" button will duplicate the valve selected and place it below. All the fields will be identical except for the decoder number which will be blank. One or more fields will need changing in order to make the decoder unique and a decoder number will need to be inserted.

To check or change the sprinklers attached to the valve click on the "OK & edit sprinklers for selected valve".

This will load the sprinklers form.

Sprinklers

Status	Sequence number	Location description	Sprinkler type	Arc
	1	Automatically added	Hunter model I31 size Orange 7	180
	2	Automatically added	Hunter model I31 size Orange 7	180
	3	Automatically added	Hunter model I31 size Orange 7	180
	4	Automatically added	Hunter model I31 size Orange 7	180
	5	Automatically added	Hunter model I31 size Orange 7	180
	6	Automatically added	Hunter model I31 size Orange 7	180
	7	Automatically added	Hunter model I31 size Orange 7	180
	8	Automatically added	Hunter model I31 size Orange 7	180

This form shows a list of the sprinklers attached to the valve (station) mentioned at the top of the form. The number of sprinklers attached is equivalent to the number that was entered in the valve form. If additional sprinklers are needed clicking on the “Insert below” button will add an extra sprinkler using the default sprinkler set up in defaults. Select the model required from the list. The mandatory fields are the sequence number and the sprinkler type. The location description is there so that an indication to the actual location of the sprinkler can be noted with reference to the valve.

Once all the sprinklers have been entered for a specific valve click on “OK”.

A small down load form will appear:

If there are no more modifications to do click on the “Download Now” button. This will then up date the entire database with all the information. This will effect the programs and schedules and so these are also updated. The sprinkler form will updated and return to the valve form.

If more updates are to happen click on the “Download Later” button. The sprinkler form will updated and return to the valve form.

If there many modifications to do it is worth clicking on the “Don't ask.....” tick box. This will cause the program not show the download box until the next time the database is updated.

Downloading Information into the Translators.

For the translators to operate correctly the station, zone and decoder numbers must be stored in the memory of the translator. The translator stores the information in a table and references the table comparing the zone number that it is given with the station number that is called on by the Aquarius software.

Every station entered into the database is given a unique number (or record). This number is in base 16, or hexadecimal. This is referred to as the station number in the translator. Each station number is given a cable or zone number to refer to. The actual decoder number is stored against this record number.

The table below illustrates this:

Unique Station Number	Zone (Cable) Number	Decoder Number
1	1	1
2	1	2
3	1	3
4	1	4
5	1	5
6	1	6
7	2	1
8	2	2
9	2	3
A	2	4
B	2	5
C	3	1
D	3	2
E	3	3
F	3	4
10	3	5

By changing the translator cable number to a new cable path the translator will now respond to the new set of station numbers without the need to re-program.

Whenever any changes to the main database are made Aquarius will try and download the new station numbers to the translators.

Once AquariusRun is started this will be the first operation carried out. Therefore, it is essential that the translators are powered up, each set to its own individual cable number, and left in the auto mode so that all the information is downloaded.

Once this has been carried out the translators are ready to communicate with Aquarius.

Creating a Program:

Before the irrigation can be run, a program containing the length of time or the amount of precipitation required per station must be created. To create a program click on the green Program button.

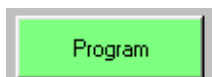

This will load up the program screen. From this screen programs can be created, edited and deleted.

The screen looks as follows:

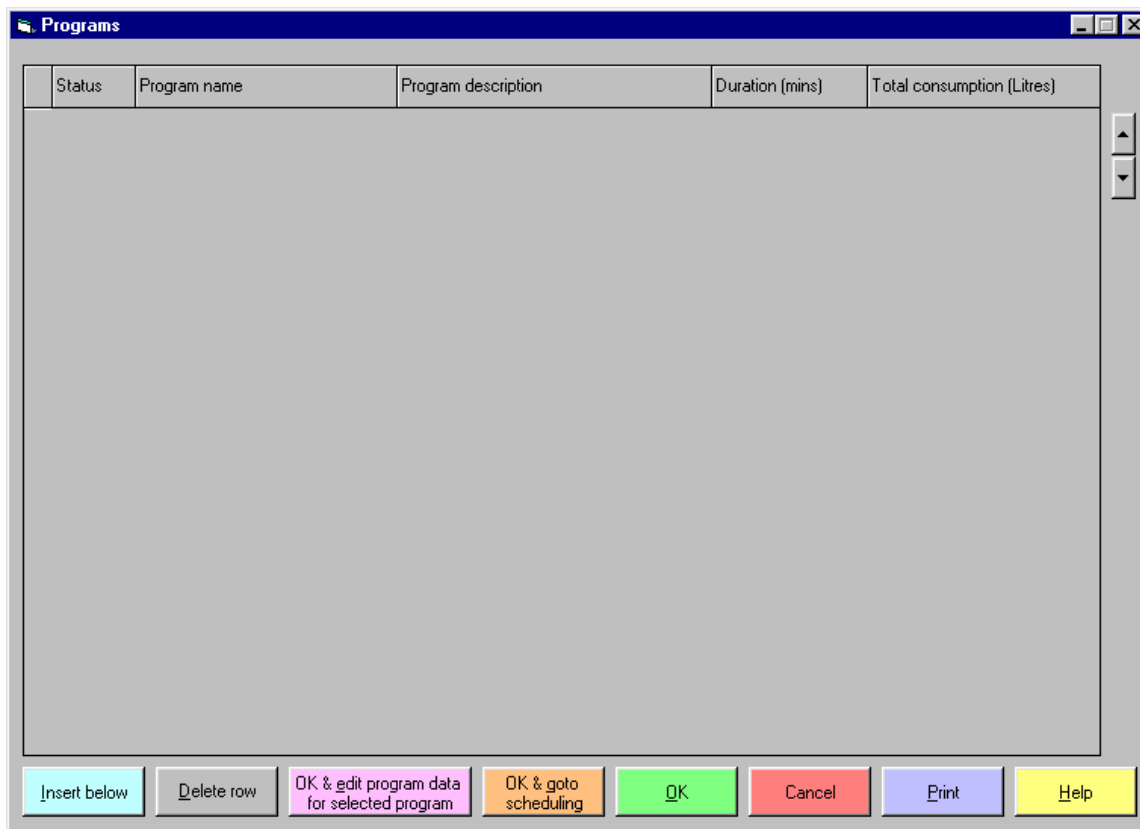

To enter a new program “click” on the “Insert below” button. An empty line will appear.

Point the mouse pointer at the box below the column labelled “Program Name” and “click” once.

Type in the name of the program that is to be produced. This could be something like “Greens Only” or “Greens and Tees 5 Mins.”

If more information is required then point the mouse at the column labelled “Program description” and “click” once. Type in a description of the program, e.g.: ‘Greens only program for the entire course’.

If there are several programs in the list the current selected one is shown by a small black arrow pointing to the left of the column labelled “Status”.

Once a program has been named “click” on the pink button labelled “OK & edit program data for selected program”. The screen will disappear after a short time and the “edit program screen will appear.

Editing a Program

The main screen for editing the data looks as follows:

Status	Course name	Hole name	Valve type	Valve sub type	Location description	Use duration	Duration (mins)	Precipitat (mm)
	Championship	Hole 1	Tee	All		<input checked="" type="checkbox"/>	0	0
	Championship	Hole 1	Fairway	1		<input checked="" type="checkbox"/>	0	0
	Championship	Hole 1	Fairway	2		<input checked="" type="checkbox"/>	0	0
	Championship	Hole 1	Fairway	3		<input checked="" type="checkbox"/>	0	0
	Championship	Hole 1	Fairway	4		<input checked="" type="checkbox"/>	0	0
	Championship	Hole 1	Fairway	5		<input checked="" type="checkbox"/>	0	0
	Championship	Hole 1	Fairway	6		<input checked="" type="checkbox"/>	0	0
	Championship	Hole 1	Green	All		<input checked="" type="checkbox"/>	0	0
	Championship	Hole 1	Walkway	All		<input checked="" type="checkbox"/>	0	0
	Championship	Hole 1	Walkway	1		<input checked="" type="checkbox"/>	0	0
	Championship	Hole 1	Surround	Right		<input checked="" type="checkbox"/>	0	0
	Championship	Hole 2	Tee	All		<input checked="" type="checkbox"/>	0	0
	Championship	Hole 2	Fairway	1		<input checked="" type="checkbox"/>	0	0
	Championship	Hole 2	Fairway	2		<input checked="" type="checkbox"/>	0	0
	Championship	Hole 2	Fairway	3		<input checked="" type="checkbox"/>	0	0
	Championship	Hole 2	Fairway	4		<input checked="" type="checkbox"/>	0	0

The programming window shows a complete list of all valves available on the system. The number of valves is shown at the top of the display below the set duration box.

There are several methods of setting the times for each station.

Method 1: To program an individual station with a basic time:

Move the mouse to the required station. "Click" in the time window. Either type in the time required (1 min – 999 Mins) or use the scroll bars in the 'Set Duration' box to reach the required time and "click" on 'Set selected station' button. The station will now be set with the desired time.

Method 2: To program a group of stations with the same basic time:

Using the different search boxes the group of stations to be programmed can be found. E.g.: To program all the greens "click on the "Search for valve location type" box. A list will appear. "Click" on the item marked "Greens" and a search will bring up a list of all the stations labelled as "greens". "Click" in the time window. Either type in the time required (1 min – 999 Mins) or use the scroll bars in the 'Set Duration' box to reach the required time and "click" on 'Set all valves' button. The stations listed will now be set with the desired time.

Method 3: To program an individual station by precipitation:

Before selecting a station click on the “Set using precipitation” button and then follow the procedures for setting times as before.

Move the mouse to the required station. “Click” in the time window. Either type in the precipitation required or use the scroll bars in the ‘Set Precipitation’ box to reach the required precipitation rate and “click” on ‘Set selected station’ button. The station will now be set with the desired precipitation.

Method 4: To program a group of stations with the same basic time:

Using the different search boxes the group of stations to be programmed can be found. E.g.: To program all the greens “click on the “Search for valve location type” box. A list will appear. “Click” on the item marked “Greens” and a search will bring up a list of all the stations labelled as “greens”.

“Click” in the precipitation window. Either type in the precipitation required or use the scroll bars in the ‘Set Duration’ box to reach the required precipitation and “click” on ‘Set all valves’ button. The stations listed will now be set with the desired precipitation.

The active column for programming is in blue. If a station was programmed by precipitation the column for precipitation will be in blue, and if it was programmed by time then the time column would be in blue.

Once a program has been set up click on ‘OK’ to return to the main program window. The duration and total consumption will now be shown for that program.

Status	Program name	Program description	Duration (mins)	Total consumption (Litres)
	Greens		10	1395

Duration and consumption are shown here

Buttons: Insert below, Delete row, OK & edit program data for selected program, OK & goto scheduling, OK, Cancel, Print, Help

More programs can be added by following the same procedures. Once all programs that are required have been written then click on the ‘OK’ button to return to the Standard Activities Form.

Alternatively by clicking on the ‘OK & goto scheduling’ button a schedule can be entered straight away.

Entering a Schedule:

To enter a schedule either click on the green Schedule button found on the standard activities form or click on the orange 'OK & goto scheduling' button found on the programs screen.

The scheduling window will appear looking as follows:

Status	Schedule name	Program name	Start date & time	Must finish by date & time	Repeat period	Number of repeats	Water budget	D
--------	---------------	--------------	-------------------	----------------------------	---------------	-------------------	--------------	---

To set a schedule click on the 'Insert below' button. A new line will appear with some limited information in it as seen below:

Status	Schedule name	Program name	Start date & time	Must finish by date & time	Repeat period	Number of repeats	Water budget	D
New			07 Oct 1999 14:55		This day only	0	100	

To create the schedule, follow these simple steps:

- 1) Click the mouse into the first column named 'Schedule name'. Type in a relevant name for the schedule you wish to run (e.g.: Greens 5 mins).
- 2) Click on the program name box. An arrow will appear. Clicking on the arrow will drop down a list of the programs that are available to schedule.

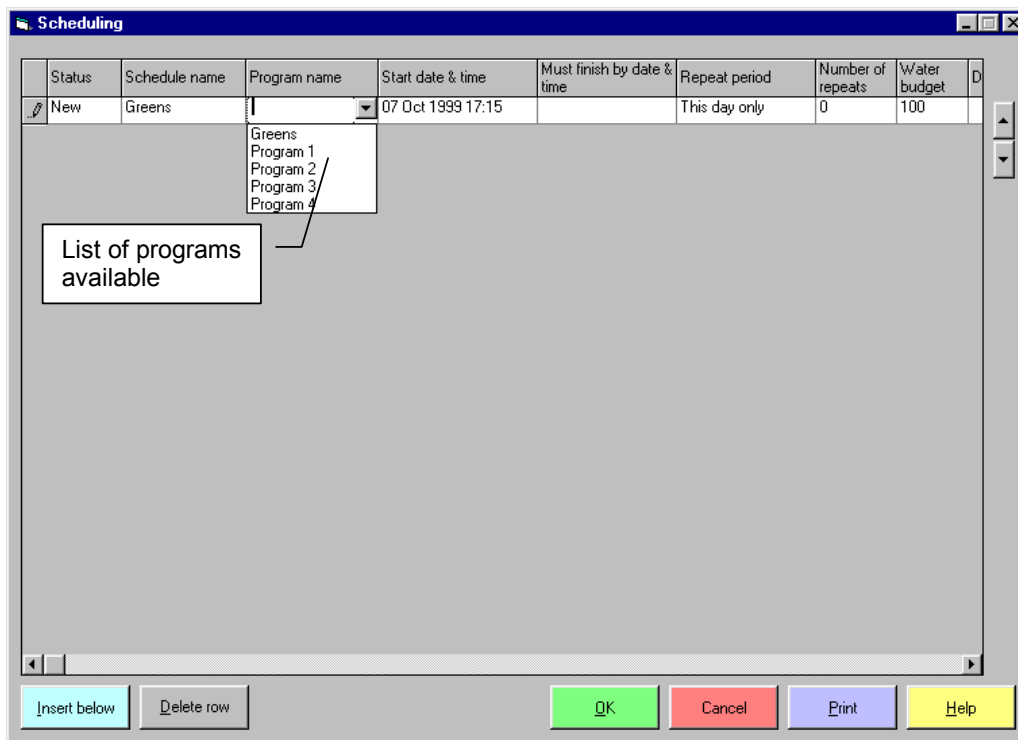

Point at the program to be scheduled and click with the mouse.

- 3) Once the program has been selected the 'Must finish by date & time' box will display a time. This time is set to the length of the duration plus 2 hours after the 'Start date & time' box. The default start Time is the current time plus 5 minutes.
- 4) To change the current start time and/or date click the mouse pointer in the 'Start date & time' box. Enter the required start time following the same format that is shown in the display. Once entered the 'Must finish by date & time' box will show a finish time of the duration plus two hours.

Note: 'Must finish by date & time' box: The 'Must finish time' has to be set to be at least the length of time of the program being run. Normally the 'Must finish by date & time' will be 2 hours longer than the program duration. This will allow for any delay caused by possible power failures so that the program will complete.

The main purpose is to set up the 'Must finish by date & time' so that the program will complete before a specified time (normally before the first Tee off time).

If there are several programs scheduled the start times can be staggered to set the order of operation (it is not necessary to work out the different start times) but it is important to ensure that the 'Must finish by date & time' is set to allow all programs to complete.

After setting the 'Must finish by date & time' the repeat period and number of repeats must be set.

- 5) 'Click' on the 'Repeat Period' box. There is a list of 4 choices. They are
 - i) 'This day only'. This option will only operate on the selected day and no other time.
 - ii) 'Every Day'. This option will operate on the selected day and for the additional number of days stated in the number of repeats window. '0' number of repeats is one day only, '3' in the number of repeats is four days (0 being day 1 and then 3 more days).
 - iii) 'Every other day' This option will only operate on every other day starting from the selected day for the number of repeats stated in the 'number of repeats' window.
 - iv) 'Every Week'. This option will only operate once a week on the selected day for the number of repeats stated in the 'number of repeats' window.

Water Budget. Any program that has been given a schedule can be increased or decreased in duration by using the water budget. The default setting for the water budget is 100%. This means that the program will run with the times as programmed originally.

To change the amount of water usage or overall run times without writing a new program simply change the water budget figure to a number lower than 100% to decrease the overall times or to a number greater than 100% to increase the times. The program will work to the nearest whole minute.

Once a schedule has been written click on the "OK" button.

A screen will appear asking if the program is to be downloaded. Click on the "Download Now" button.

The schedule information is now loaded into Aquarius Run and will wait for the appropriate time before starting.

If more programmes are to be added within a short period of time then click on "Download Later" add more programmes and after scheduling them then select "Download Now".

IMPORTANT if the "Download Now" button is not selected none of the programmes scheduled will run!

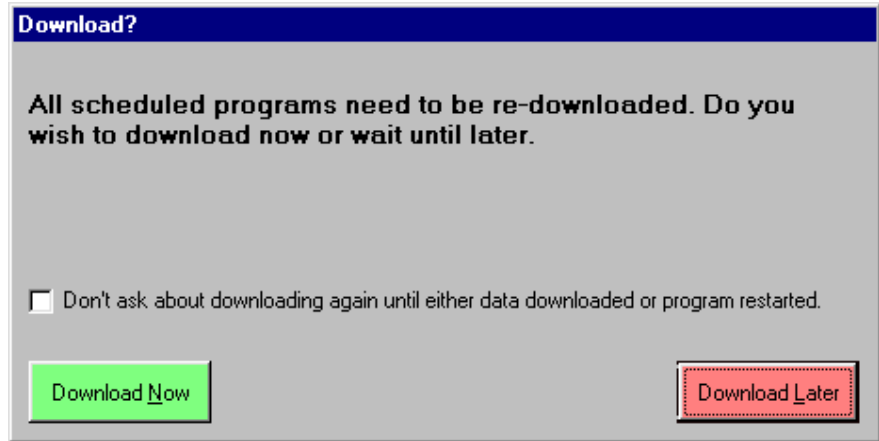

Manual operation.

Aquarius Universal has a manual operation option. To turn on valves and run them manually click on the manual button.

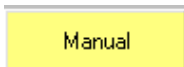

The manual operation screen will now load.

Searches for finding the correct station.

Ignore hydraulics tick box
Button.

To select a station to operate in manual use the search boxes at the top of the screen. Once the station or group of stations have been found, use the program time box (this is the same as writing a program) to set either the run time or the required precipitation. Click on either “Set selected valve” to program the selected station or click on “Set all valves” to program all the valves shown in the list. This will set the times to the valves that are required for manual operation.

Clicking on the “Copy valves chosen to run to lower table and run them” button will move the list of selected valves into the lower table. The program will then run the maximum number of valves it can without exceeding the electrical and hydraulic configuration. To ignore the hydraulic configuration click on the box labelled “Ignore Hydraulics” before copying the valves into the run list. This will then only take the electrical constraints into consideration when operating valves.

If it is not desirable to run more than one group of valves at a time (for example only allowing one green to operate at a time) use the “Start new valve group” button. This will set a new group each time a selection is added to the run list. None of the new group will commence watering until the previous group has completed. Only then will the next group in the list start. Within a group all constraints of electrical and hydraulic configurations will apply.

To pause a valve click on the “pause” button. This will pause the selected valve until resume is clicked on. These buttons only appear when one or more valve is in the run table.

To cancel manual click on the “Kill all valves” button. This too will only appear when one or more valve is in the run table.

When manual has been completed then click on “Cancel”. After a few minutes the Standard Activities Screen will reappear.

Diagnostic Operation.

A diagnostic program can be run from Aquarius in order to test that the various decoders are all fully functioning and the sequence is correctly set up.

To run a diagnostic test click on the Diagnostic button
This will load up the following screen:

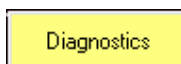

This will load up the diagnostics screen. From this screen diagnostic programs can be created, edited and deleted.

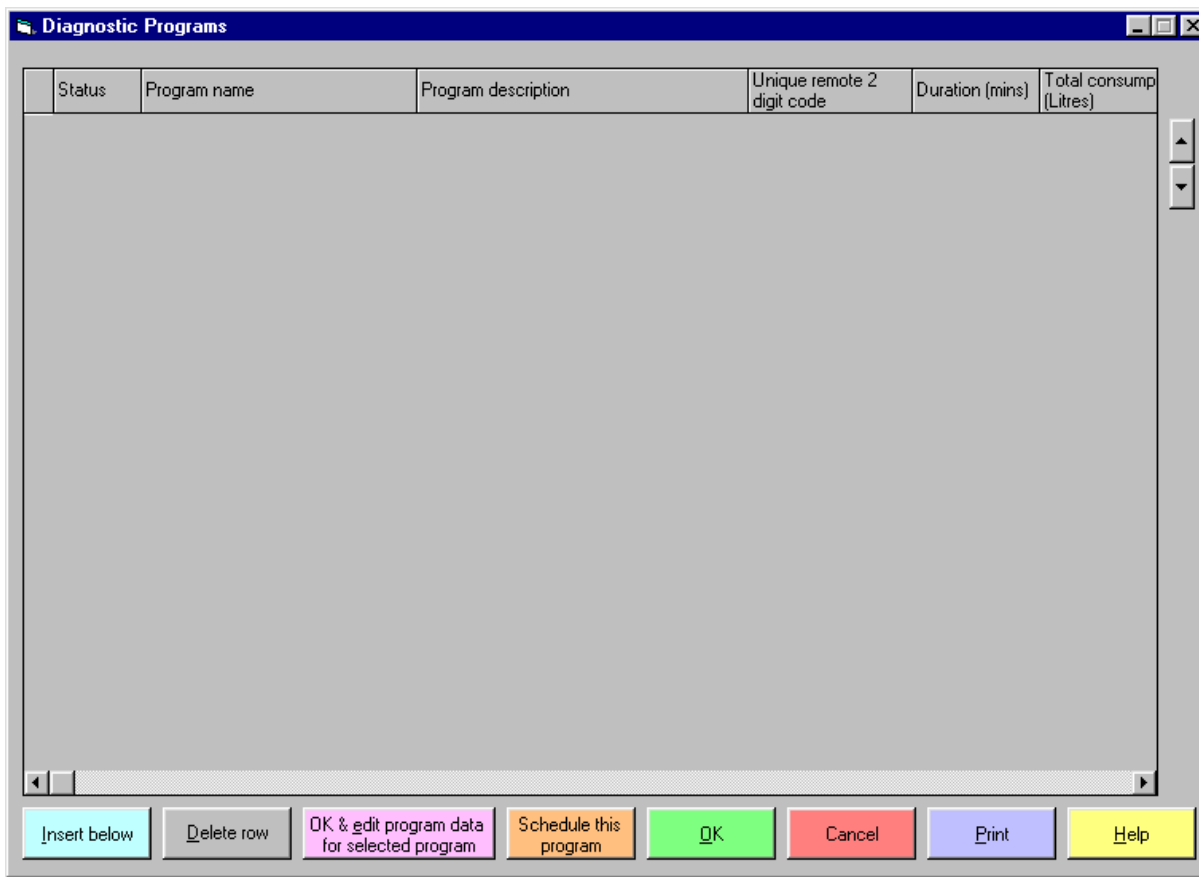

To enter a new diagnostic program “click” on the blue “Insert below” button. A white line will appear along the top of the table.

Point the mouse pointer at the box below the column labelled “Program Name” and “click” once.

Type in the name of the program that is to be produced. This could be something like “Test all for 6 seconds” or “Hole 5 test”.

If more information is required then point the mouse at the column labelled “Program description” and “click” once. Type in a description of the program, e.g.: “Full test for the entire course”.

Enter in a unique remote code. This is for a feature that will become available shortly. It will soon be possible to start a diagnostic program from the radio handset if a remote control system is installed.

If there are several programs in the list the current selected one is shown by a small black arrow pointing to the left of the column labelled “Status”.

Once a program has been named “click” on the pink button labelled “OK & edit program data for selected program”. The screen will disappear after a short time and the “edit program screen will appear.

Editing a Diagnostics Program

Status	Course name	Hole name	Valve type	Valve sub type	Location description	Duration (mins)	Pause before operating (mins)
▶	Championship	Hole 1	Tee	All		0	0
	Championship	Hole 1	Fairway	1		0	0
	Championship	Hole 1	Fairway	2		0	0
	Championship	Hole 1	Fairway	3		0	0
	Championship	Hole 1	Fairway	4		0	0
	Championship	Hole 1	Fairway	5		0	0
	Championship	Hole 1	Fairway	6		0	0
	Championship	Hole 1	Green	All		0	0
	Championship	Hole 1	Walkway	All		0	0
	Championship	Hole 1	Walkway	1		0	0
	Championship	Hole 1	Surround	Right		0	0
	Championship	Hole 2	Tee	All		0	0
	Championship	Hole 2	Fairway	1		0	0
	Championship	Hole 2	Fairway	2		0	0
	Championship	Hole 2	Fairway	3		0	0
	Championship	Hole 2	Fairway	4		0	0
	Championship	Hole 2	Green	All		0	0

The main screen for editing the data looks as follows:

For every station in the list a pause time can be added, this must be whole minutes. The run time for each individual station can be from 0.1minutes (6 seconds) in 0.1 minutes increments to 99 minutes.

This very useful when trying to run a test program that allows the user to follow the program round the site. By setting the pause between two stations it is possible to get from one station having seen it close and arrive at the next before it opens. This will prevent the necessity of rushing to try and keep up with the system.

The programming window shows a complete list of all valves available on the system. The number of valves is shown at the top of the display below the set duration box.

There are several methods of setting the times for each station.

Method 1: To program an individual station with a basic time:

Move the mouse to the required station. "Click" in the time window. Either type in the time required (1 min – 99 Mins.) or use the scroll bars in the 'Set Duration' box to reach the required time and "click" on 'Set selected station' button. The station will now be set with the desired time.

Method 2: To program a group of stations with the same basic time:

Using the different search boxes the group of stations to be programmed can be found. E.g.: To program all the greens "click on the "Search for valve location type" box. A list will appear. "Click" on the item marked "Greens" and a search will bring up a list of all the stations labelled as "greens".

“Click” in the time window. Either type in the time required (1 min – 999 Mins) or use the scroll bars in the “Set Duration” box to reach the required time and “click” on “Set all valves” button. The stations listed will now be set with the desired time.

Method 3: To program an individual station by precipitation:

Before selecting a station click on the “Set using precipitation” button and then follow the procedures for setting times as before.

Move the mouse to the required station. “Click” in the time window. Either type in the precipitation required or use the scroll bars in the ‘Set Precipitation’ box to reach the required precipitation rate and “click” on ‘Set selected station’ button. The station will now be set with the desired precipitation.

Method 4: To program a group of stations with the same basic time:

Using the different search boxes it is possible to find the group of stations to be programmed. E.g.: To program all the greens click on the “Search for valve location type” box. A list will appear. Click on the item marked “Greens” and a search will bring up a list of all the stations labelled as “greens”.

Click in the precipitation window. Either type in the precipitation required or use the scroll bars in the ‘Set Duration’ box to reach the required precipitation and click on ‘Set all valves’ button. The stations listed will now be set with the desired precipitation.

The active column for programming is in blue. If a station was programmed by precipitation the column for precipitation will be in blue, otherwise the time column would be in blue.

Once a program has been set up click on ‘OK’ to return to the main program window. The duration and total consumption will now be shown for that program.

Status	Program name	Program description	Unique remote 2 digit code	Duration (mins)	Total consump (Litres)
	Test All for 6 seconds	Complete Test	01	47	11106

Once a diagnostic program has been created it will be stored until it is deleted. It can be scheduled to start by clicking on the “Schedule this program” button.

A small window will appear. If the start time displayed in the window is not the desired time then click in the time box with the mouse pointer and delete the time and enter a new time. Click on "OK" and the box will disappear. At the allotted time the diagnostic program will start.

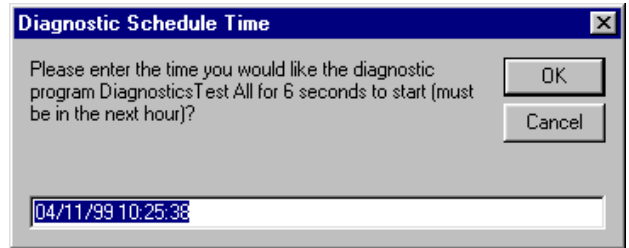

Remote Control

To use the remote control a radio interface system is required.

To install refer to Appendix E.

Once the remote control is installed there are two ways of accessing the remote.

1) Starting from the standard activities form.

Click on the button marked "Remote". This will start the remote form as seen below.

2) Using the radio handset.

Using the radio handset (for example if you are already out on the site) dial 123* from the keypad. This will activate the remote option of Aquarius. This number can be changed at any time.

Aquarius Remote

The system is in remote mode. No schedule will run until the system is taken out of remote mode.

Remote Codes:

Pause	777#	Kill diagnostics	200#	Run diagnostic program	2nn#	Bypass this delay	665#
Start/Resume	888#	Start new group	555#	Run next valve in seq	661#	Run next valve in seq (no delay)	662#
Clear buffer	B (CLR)	Set default duration	1nn#	Run previous valve in seq	669#	Run prev valve in seq (no delay)	668#

Activate remote mode *
 Emergency shut all valves *
 Default valve on duration (in Minutes)

Use valve ref followed by # to switch valve ON and valve ref followed by * to switch valve OFF.
 When a diagnostic program is running all other remote codes that affect running valves will cause it to stop.

Ignore hydraulics

Input pending:

All inputs:

Valve set to operate: Current group number is 1

Operational status	Group	Course name	Hole name	Valve type	Valve sub type	Duration (mins)	Duration to go (mins)

Remote codes available:

Duration: The default duration of the remote is set to 5 minutes. To change this duration either type in the new duration in the duration box or, using the radio handset dial **1nn#**. The nn signifies the new duration in minutes. For 1 minute dial **101#**.

To turn on a valve: The dial sequence is **C, HH, VTVT, VSTVST,#** using the unique remote codes that are set when the database is set up.

C = Course (1 digit unless there are more than ten courses).
HH = Hole (2 digits. Typically 01 for hole 1, 10 for hole 10).
VTVT = Valve location type (2 Digits. E.g.: 01 for greens, 02 for Tees etc)
VSTVST = Valve location sub type (2 Digits. E.g.: 01 for back left etc or 00 for all stations of the valve type group).)

Dialling the same number but with * at the end will turn the valve off.

Emergency shut down:

In the event that all valves must be shut off in a hurry dial **999*** This number can be changed to suit the individual system.

Pause:

To pause a station dial **777#**.

Resume:

To resume the valve(s) after pausing dial **888#**.

Clear Buffer:

If, while dialling a number, you make a mistake the number can be cleared by dialling **B** from the radio handset. On the HX390 select this is the "Clear" button which is pressed while keying the mike.

Running a Diagnostics program:

Once a diagnostics program has been created in diagnostics it is possible to start the program from the radio handset by dialling **2nn#**, where nn is the 2 digit remote code of the diagnostics program.

Kill Diagnostics:

Dialling **200#** will kill any diagnostics program that is running.

Bypassing delays:

Using **665#** will tell Aquarius to ignore the delay if programmed into the diagnostic program currently running.

Logbooks

Aquarius has two logbooks. The main daily logbook and the water consumption logbook.

The Main Logbook

The main logbook is accessed by clicking on the



button on the standard activities screen. The Logbooks form will appear.

Date time	User name	Logbook entry	Code	Monitor type	Error entry
02 Mar 2000 08:26	Administrator	Logged on.	101	Not Applicable	<input type="checkbox"/>
01 Mar 2000 15:36	Administrator	Logged off.	102	Not Applicable	<input type="checkbox"/>
01 Mar 2000 14:51	Administrator	Logged on.	101	Not Applicable	<input type="checkbox"/>
01 Mar 2000 14:13	Administrator	Logged on.	101	Not Applicable	<input type="checkbox"/>
01 Mar 2000 14:13	Administrator	Someone tried to log on as this user but failed.	111	Not Applicable	<input checked="" type="checkbox"/>
29 Feb 2000 12:07	Administrator	Logged off.	102	Not Applicable	<input type="checkbox"/>
29 Feb 2000 12:07	Administrator	Logged on.	101	Not Applicable	<input type="checkbox"/>
29 Feb 2000 12:04	Administrator	Logged off.	102	Not Applicable	<input type="checkbox"/>
29 Feb 2000 12:04	Administrator	Logged on.	101	Not Applicable	<input type="checkbox"/>
29 Feb 2000 12:01	Administrator	Logged off.	102	Not Applicable	<input type="checkbox"/>
29 Feb 2000 12:00	Administrator	Logged on.	101	Not Applicable	<input type="checkbox"/>
28 Feb 2000 16:21	Administrator	Logged on.	101	Not Applicable	<input type="checkbox"/>
21 Aug 1999 09:40	Administrator	Logged off.	102	Not Applicable	<input type="checkbox"/>
21 Aug 1999 09:25	Administrator	Logged on.	101	Not Applicable	<input type="checkbox"/>
21 Aug 1999 09:19	Administrator	Logged off.	102	Not Applicable	<input type="checkbox"/>
21 Aug 1999 09:19	Administrator	Logged on.	101	Not Applicable	<input type="checkbox"/>
21 Aug 1999 09:19	Peter Creary	Logged off.	102	Not Applicable	<input type="checkbox"/>
21 Aug 1999 09:19	Peter Creary	Logged on.	101	Not Applicable	<input type="checkbox"/>

Everything that occurs when operating Aquarius Universal is logged in the logbook. To view only the items that are of interest click on the tick boxes to select the item to view.

User logbook: This logs all the users who have either logged on or off from the system.

System Logbook: This logs events such as power failures while the program is operating.

Operation Logbook: This logs all the operation events such as Programs that have run, when Manual, Diagnostic and Remote were used.

Water Consumption Logbook: This records how much water was used by programs (including Manual etc).

Ticking the various options and clicking on the “Apply this search criteria and refill list” button will update the list to display only the events that are of interest.

If a tick appears in the Error enter column the “Show additional information for entry” button will become active. Clicking on this button will display the list of errors that occurred during that event (usually a program).

Entries to the logbook can only be deleted by an authorised user. The permission for this is set by the administrator in the “Set up Users” form.

Water Consumption Logbook

The Water consumption logbook records all the water usage of all programs and other operations.

To view the Water consumption logbook click on the

Show water consumption

button. The Water consumption logbook screen will appear:

Sum period	Total (Cubic Metres)	Programmes (Cubic Metres)	Manual operation (Cubic Metres)	Remote operation (Cubic Metres)	Diagnostic operation (Cubic)
► Grand total	7772.9	6883.3	839.8	49.8	0
09/08/99 02:32:28	24.9	24.9	0	0	0
09/08/99 00:52:48	17.5	17.5	0	0	0
08/08/99 23:42:20	25	25	0	0	0
08/08/99 22:22:52	17.5	17.5	0	0	0
08/08/99 21:32:21	25	25	0	0	0
07/08/99 05:32:22	25	25	0	0	0
07/08/99 03:42:47	17.5	17.5	0	0	0
07/08/99 02:32:26	25	25	0	0	0
07/08/99 00:52:47	17.5	17.5	0	0	0
06/08/99 23:42:22	24.9	24.9	0	0	0
06/08/99 22:22:47	17.5	17.5	0	0	0
06/08/99 21:32:28	25	25	0	0	0
06/08/99 06:11:56	14.3	0	14.3	0	0
06/08/99 05:16:25	26.2	26.2	0	0	0
06/08/99 03:46:21	26.2	26.2	0	0	0
06/08/99 02:32:39	25	25	0	0	0
06/08/99 00:52:55	17.5	17.5	0	0	0

Period to sum over:
 Period from: to
 Show every period

Default start time of day (hh:mm):
 Default start month:

Default start day of week:
 Default start day of above month:

The Water consumption logbook gives a complete list of all water usage. This, over time, will become a large list of information. The information can be restricted to specific time periods. To achieve this use the "Period to sum over" search box to select the viewing period and set the dates to be viewed with the date boxes at the top of the screen.

The viewing options available are:

- Daily:** This will display the list of water usage for every day shown in the set period. The changeover time is set in the "Default start time of day" box.
- Weekly:** This will display the list of water usage on a weekly basis over the set period. The changeover time is set in the "Default start time of day" and "Default start day of the week" boxes.
- Monthly:** This will display the list of water usage on a monthly basis over the set period.
- Yearly:** This will display the list of water usage on a yearly basis over the set period. The changeover time is set in the "Default start month" and "Default start day for the above month" boxes.

If the viewing option is always required clicking on the "Save above defaults" button will ensure that every time the Water consumption logbook is opened the desired view is shown.

AquariusRun

Aquarius Run is the program that actually communicates with the translators. It takes all the data relating to the run times and start times that is stored in the database and at the allotted times turns valves on and off.

If AquariusRun has not been automatically started when Windows starts there will be a large button on the Standard activities form. If this button is visible the AquariusRun program has not been activated.



To start AquariusRun either click on the button or on "Manual", "Diagnostics" or "Remote". Whenever any of these programs are instigated AquariusRun will be started.

The AquariusRun screen contains a menu and a controller monitor display.

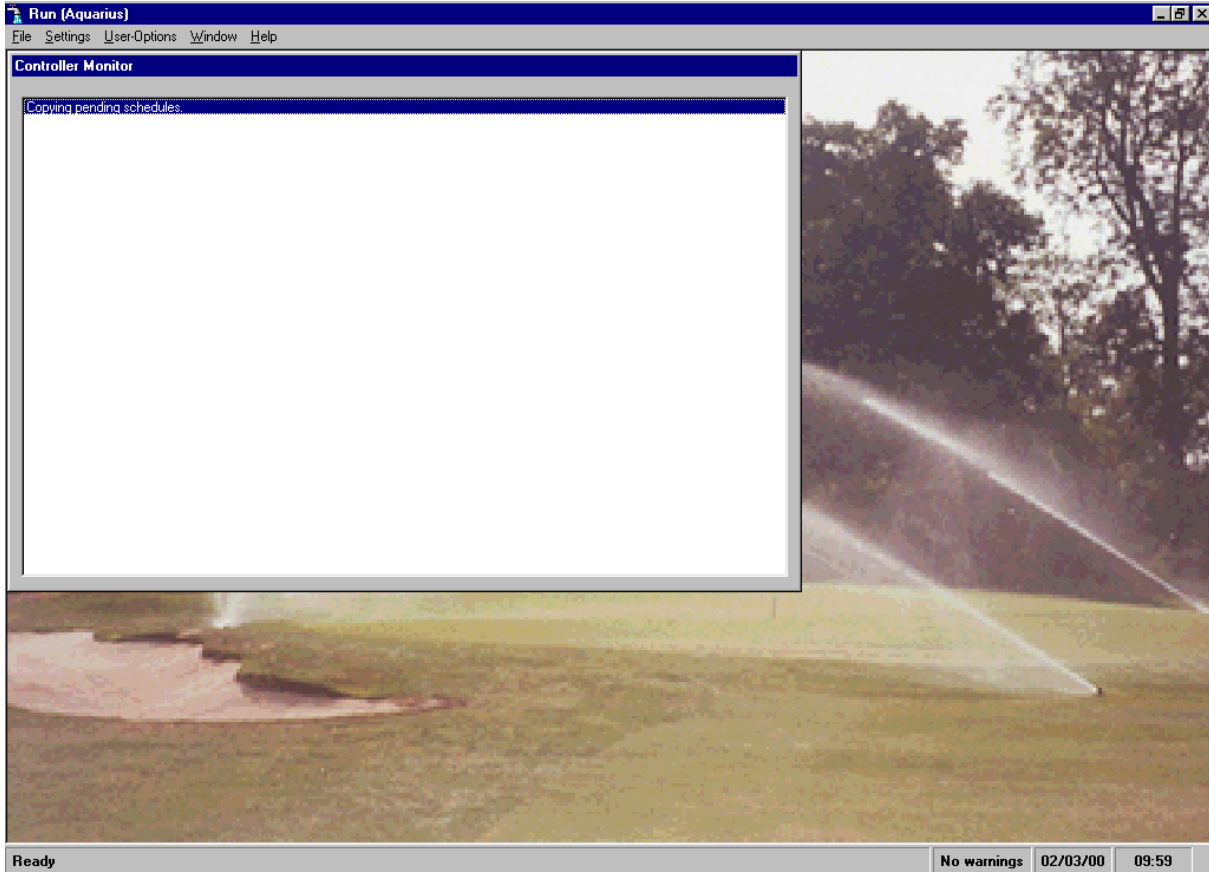

The main feature of the AquariusRun screen is the controller monitor. The menu structure is shown in **Appendix D**.

Whenever a valve is signalled to turn on or off a message indicating the command is displayed in the controller monitor screen.

Additional information can be viewed by pointing the mouse at the bottom of the controller monitor screen and when a vertical double arrow appears press the left button of the mouse and drag down. Several tick boxes will appear as shown in the screen below:

Additional information in the Controller monitor screen.

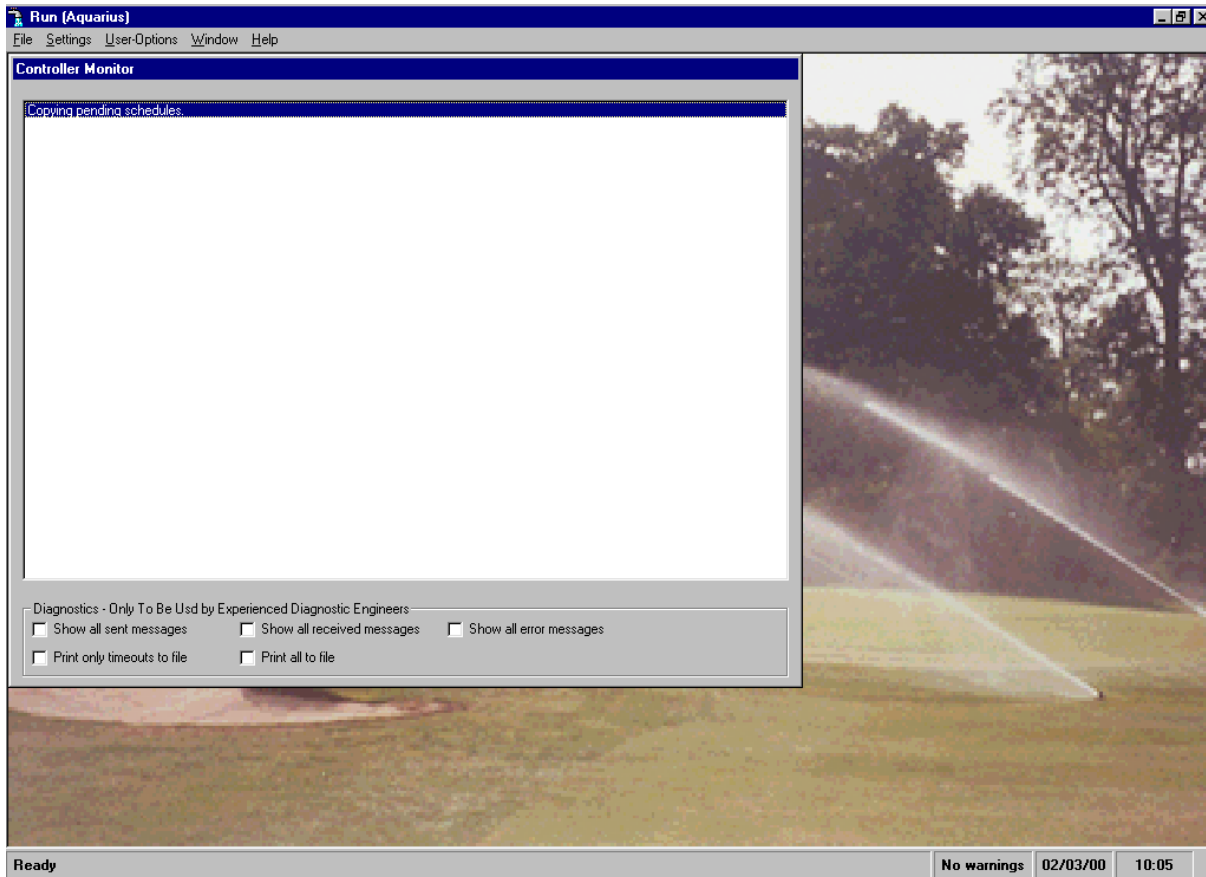

By ticking the various boxes additional information can be shown or stored.

- “Show all sent messages”:** This will display the actual line of commands that are sent to the Translators.
- “Show all received messages”:** This will display the actual line of commands that are received from the Translators.
- “Show all received messages”:** This will display the error messages that occur during the signalling process.
- “Print only timeouts to file”:** If a Translator fails to respond to the signal the program will eventually stop trying to communicate and issue a “Timeout” message. If this a regular problem these messages can be recorded by ticking this box. All timeout messages (including a log of date and time) will be recorded in a text file called “Timeout.txt” stored in the Aquarius directory.
- “Print all to file”:** If all messages are to be recorded this can be done by ticking this box. Now all messages will be saved to a file named “Myerror.txt” which is stored in the Data directory of Aquarius. It may be advisable, if several errors are occurring, to use this option so that all error messages and codes that have been sent and received can be viewed once printed out onto paper.

Cancelling AquariusRun will stop all programs from continuing if they are already in operation.

APPENDIX A: Changing the District and Area labels in Aquarius.

To change the labels for both district and area click on “File” on the menu bar and select “Properties”.

There are two fields to note, the District Label and Area label.

The screenshot shows the 'Properties' dialog box with the following fields and values:

Site name	Site Name
Person responsible for this database	Administrator
Maintenance contract number	
Maintenance contract contact person	Peter Madden
Maintenance contract phone number	01483 267400
Web site address	www.avnet/logicirrigation
Sales phone number	01483 894892
Country	UK
District label	District
Area label	Area
Default units to use when setting a new user	Metric
Comments	You can put additional comments here

Callout boxes provide instructions:

- Enter the new label for the district here.
- Enter the new label for the area here.

Buttons: OK (highlighted), Cancel, Help

Once these are entered, everywhere the word “District” would appear will be replaced by the word entered in the District label box, and everywhere the word “Area” would appear will be replaced by the word entered in the Area label box.

Appendix B: Setting preferences for individual users

As every user has their own preferences relating to the units that are used throughout the program it is possible to set the units in Aquarius to suit each users requirements.

To set the units click on the menu bar option “User-options” followed by “Preferences”.

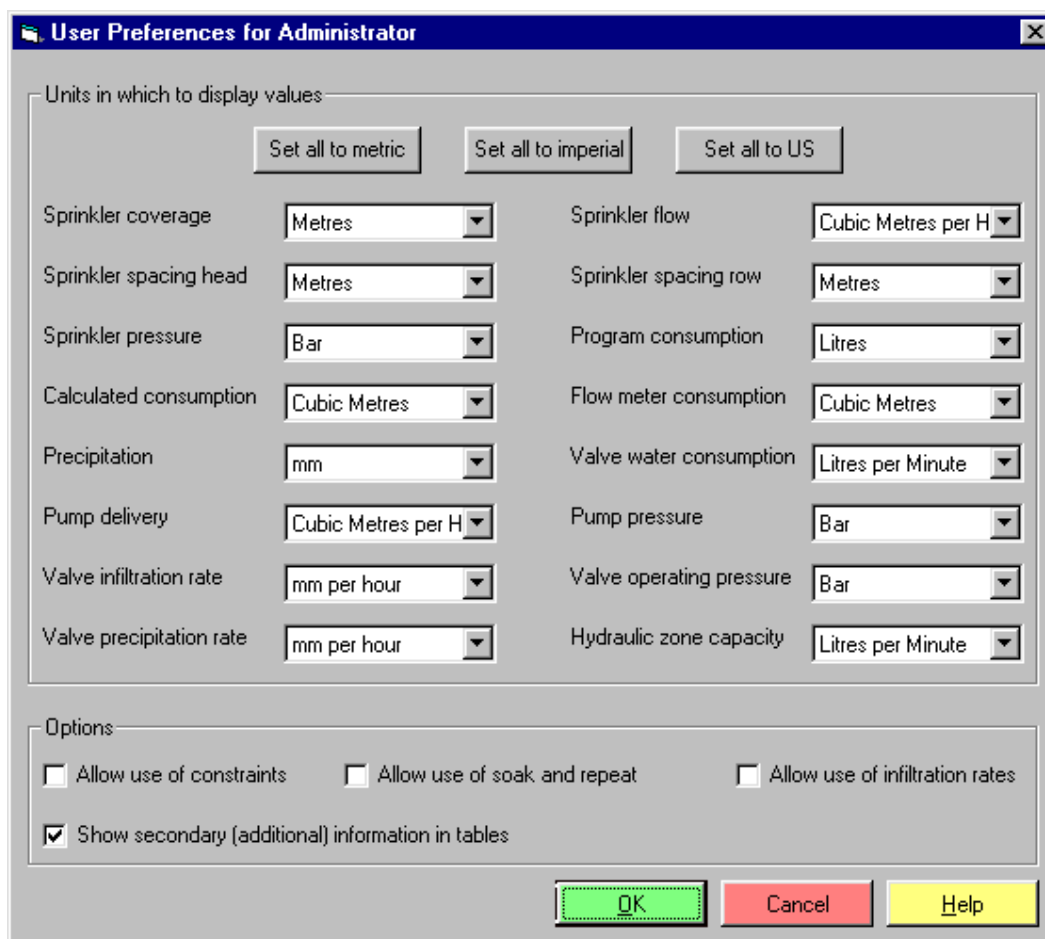

User Preferences for Administrator

Units in which to display values

Set all to metric Set all to imperial Set all to US

Sprinkler coverage	Metres	Sprinkler flow	Cubic Metres per H
Sprinkler spacing head	Metres	Sprinkler spacing row	Metres
Sprinkler pressure	Bar	Program consumption	Litres
Calculated consumption	Cubic Metres	Flow meter consumption	Cubic Metres
Precipitation	mm	Valve water consumption	Litres per Minute
Pump delivery	Cubic Metres per H	Pump pressure	Bar
Valve infiltration rate	mm per hour	Valve operating pressure	Bar
Valve precipitation rate	mm per hour	Hydraulic zone capacity	Litres per Minute

Options

Allow use of constraints Allow use of soak and repeat Allow use of infiltration rates

Show secondary (additional) information in tables

OK Cancel Help

If the user can set everything to be either Metric, Imperial or US units by simply clicking on the appropriate button. This will set all the attributes to the required units.

It is also possible to set each attribute to any unit. To do this simply select the attribute that needs to be changed and a list of the various options will drop down. Select the unit that is required and it will set the program to that unit.

Every user can set their own units so that each time they log on Aquarius will set up their preferred units.

At the bottom of the form is a section called “Options”. If the “Show secondary (additional) information in tables” is ticked extra columns in the valve form will be visible. If this information is not necessary leave the box un-ticked.

Appendix C: Files stored in Aquarius

Aquarius Universal will be stored in a sub directory of Program Files;

The main directory is: C:\Program Files\Aquarius.

There are three sub directories found in the Aquarius directory:

Data. This contains the databases for the main program as well as the graphics file (if used)

Demo. This contains the databases and the graphics file for the demo program.

Key. This contains information relating to the security key that is plugged into the parallel port of the

Below is a list of the most important files found in the Aquarius directory.

Aquarius Directory:

Aquarius.exe	The main program
AquariusRun.exe	The communications program.
AquariusWatch.exe	The watch dog program
Timeout.txt	This stores all timeout information from AquariusRun providing the print timeout option is selected

Aquarius\Data Directory

AquariusLive.mdb	The main database. This stores all the information about the site.
AquariusRun.mdb	The operational database. This stores all the information about when valves have to operate and for how long.
AquariusHW.mdb	The hardware settings database.
Aquariusmap.mpd	This is the drawing of the course if the graphics option is enabled.
Myerror.txt	This stores all messages from AquariusRun providing the print all messages option is selected

Aquarius\Demo Directory

AquariusLive.mdb	The demo database. This stores all the information about the site.
Aquariusmap.mpd	This is the drawing of the demo course if the graphics option is enabled.

Aquarius\key Directory

This directory stores all the information relating to the security key attached to the computer.

Appendix D: Aquarius Menus

Aquarius Universal Menu

File-----	--Logon --Logoff --Properties --Backup Database --Restore Database --Exit
Logbooks-----	--Show logbook --Show water consumption
Programming-----	--Set up a program --Schedule a program
Run-----	--Re-download decoder data --Re-download program schedule data --Run a schedule --Manual --Diagnostics --Remote
Setup-----	--Users --Data----- --District --Area --Valve location type --Valve location subtype --Valve type --Sprinklers --Default values --Site----- --Pump Houses --Hydraulic zones --Controller zones --Valves --View all sprinklers --Comm port setting --Graphics
User-options-----	--Preferences --Change Password
Weather data-----	--Read current ET (Available late 2000) --Run Weather station program (Available late 2000)
Window -----	--Show Activities form --Standard activities and system status
Help-----	--Application Help --About

AquariusRun Menu

```
File-----|
           |--Exit
Settings----|
           |--Comm port settings
User-options--|
           |--Change Password
Window -----|
           |--Controller Monitor
Help-----|
           |--About
```

Appendix E: Adding a remote control to Aquarius.

To add a radio remote control system to Aquarius the following equipment is required:

- 1 x LR10 Logic Radio remote modem interface unit
- 1 x HX390 select radio handset with DTMF keypad
- 1 x Battery charger for HX390
- 1 x Serial connection lead (included with the LR10).
- 1 x Power supply for LR10 (included with the LR10).

Connect the Radio modem unit to a spare serial port in the back of the PC (usually Comm. 2).

Start Aquarius Universal or AquariusRun.

In Aquarius Universal select "Settings" from the menu bar. Select the "Comm port settings".

The display shows a list of comm. ports available.

Note: Only the administrator can set up or change the ports.

To activate the remote control select the port number that the receiver has been connected to (this must be different from the controller port setting).

The default baud rates and other settings should not be changed.

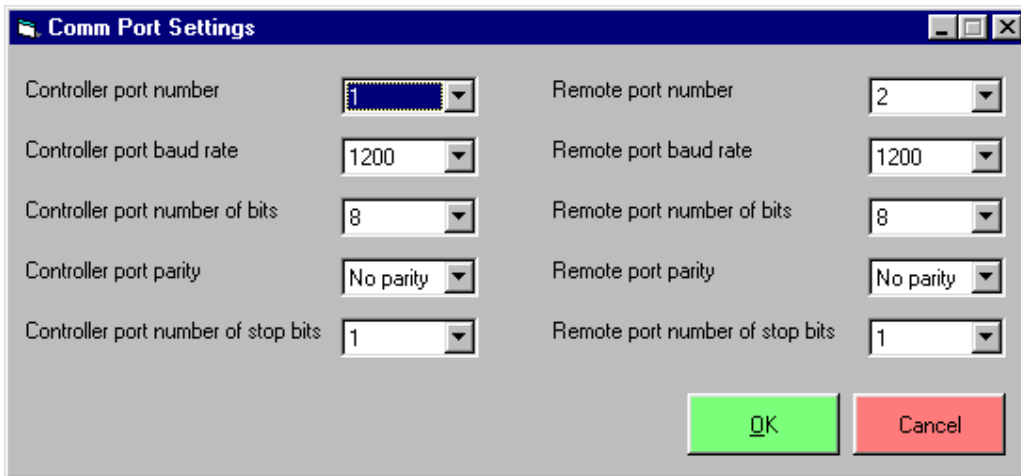

Controller port	Remote port
Controller port number	Remote port number
Controller port baud rate	Remote port baud rate
Controller port number of bits	Remote port number of bits
Controller port parity	Remote port parity
Controller port number of stop bits	Remote port number of stop bits

Once all the settings are confirmed clicking on "OK" will save the settings. If AquariusRun is operational it will be necessary to close it down and restart it for the port settings to take effect.

The same settings can be changed from AquariusRun from the menu bar. Select "Settings" and "Comm port settings". Set up the ports as before and click on OK. This time a request for a password will appear. The default password is "password". Once this has been entered the port settings are saved.

The remote control is now ready for operation.

Appendix F: Logic Aquarius Database information:

General Site information

Courses

Please fill in the name of the courses that you require

Course	Description (if required)

Valve Types

Please enter the different valves that are installed on each course. Include the normal closing time for each valve.

Valve Manufacturer	Valve Model	Size	Closing time (secs)

Valve Types:

This information is asking for whether a station is a Green, Tee Approach, Putting Green etc.:

Valve Type	Description

Valve Sub types:

This information is asking for whether a station belonging to a Green, Tee Approach, Putting Green etc. is back left, left, right complete. E.g.: if the green is double valved then the Valve Type would be Green and the Valve Sub Type would be Left or Right.

Valve Sub Type	Description

Information about what is installed and how the system is set up.

Pump House: Please enter the pump house and the information regarding the pumps and performance.

Pump House Name	Description	Operating Pressure

Pumps within a Pump House: For the delivery please enter the required performance for the system.

Pump-house	Pump Name	Description	Delivery

Hydraulic Zones: Please enter in how many hydraulic zones and what the expected flow for each zone will be.

Hydraulic Zone Name	Description	Capacity	Pump House

If you are not sure fill out as much as is possible and then I can sort out the rest when we install the system.

Feel free to make as many copies as you require before starting.

© Evenproducts Limited. This manual is produced by:

Evenproducts Limited The Oxstalls Evesham
Worcestershire WR11 4TU

Telephone: +44 (0) 1386 760 950

Fax: +44 (0) 1386 423 769

We reserve the right to change, alter or modify this manual without prior notice.

ISSUE 2 –07/2004



EVENPRODUCTS

water for life

WATER STORAGE TANKS
HORTICULTURAL IRRIGATION
EMERGENCY WATER AID
SPORTS TURF IRRIGATION
LANDSCAPE IRRIGATION

For more information contact:

EVENPRODUCTS LIMITED

The Oxstalls
Evesham
Worcestershire WR11 4TU
United Kingdom

Switchboard t: 01386 412 12
SALES t: 01386 760 950
f: 01386 423 769
e: sales@evenproducts.com